

# Automaton semigroups: new constructions results and examples of non-automaton semigroups

Tara Brough and Alan J. Cain

## Abstract

This paper studies the class of automaton semigroups from two perspectives: closure under constructions, and examples of semigroups that are not automaton semigroups. We prove that (semigroup) free products of finite semigroups always arise as automaton semigroups, and that the class of automaton monoids is closed under forming wreath products with finite monoids. We also consider closure under certain kinds of Rees matrix constructions, strong semilattices, and small extensions. Finally, we prove that no subsemigroup of  $(\mathbb{N}, +)$  arises as an automaton semigroup. (Previously,  $(\mathbb{N}, +)$  itself was the unique example of a finitely generated residually finite semigroup that was known not to arise as an automaton semigroup.)

## 1 Introduction

Automaton semigroups (that is, semigroups of endomorphisms of rooted trees generated the actions of Mealy automata) emerged as a generalisation of automaton groups, which arose from the construction of groups having ‘exotic’ properties, such as the finitely generated infinite torsion group found by Grigorchuk [10], and later proven to have intermediate growth, again by Grigorchuk [8]. The topic of automaton groups has since developed into a substantial theory; See, for example, Nekrashevych’s monograph [18] or one of the surveys by the school led by Bartholdi, Grigorchuk, Nekrashevych, and Šunić [1, 2, 7].

After the foundational work of Grigorchuk, Nekrashevych & Sushchanskii [9, esp. Sec. 4 & Subsec. 7.2], the theory of automaton semigroups has grown into an active research topic. Broadly speaking, there have been two foci of research. First, the study of decision problems: what can be effectively decided about the semigroup generated by a given automaton? For example, the finiteness and torsion problems are now known to be undecidable for general automaton semigroups [6], but particular special cases are decidable [14, 13, 16]. Second, the study of the class of automaton semigroups: which semigroups arise and do not arise as automaton semigroups? Two particular aspects of this question are

whether the class of automaton semigroups is closed under various semigroup constructions, and giving examples of semigroups that do not arise as automaton semigroups. This paper is concerned with both of these aspects.

For some constructions, such as direct products and adjoining a zero or identity, it is straightforward to prove that the class is closed; see [4, Section 5]. For many other natural constructions, the question of closure remains open. For example, whether automaton semigroups are closed under free products is an open question. (This is related to the problem of showing that all free groups arise as automaton groups; the recent positive answer to this question was the culmination of the work a series of authors; see [22] and the references therein.) The free product of automaton semigroups is, however, at least very close to being an automaton semigroup: in a previous paper, we showed that  $(S \star T)^1$  is always an automaton semigroup if  $S$  and  $T$  are [3, Theorem 3].

Since closure under free products seemed difficult to settle, the second author asked whether free products of finite semigroups always arise as automaton semigroups [4, Open problem 5.8(1)]. In [3, Conjecture 5], we conjectured that the answer was ‘no’, and suggested a potential counterexample. However, in this paper we prove that the answer is ‘yes’: free products of finite semigroups always arise as automaton semigroups (Theorem 2). This parallels the result that (group) free products of finite groups arise as automaton groups [11]. More generally, we show in Theorem 3 that the free product of automaton semigroups each containing an idempotent is always an automaton semigroup.

In our previous paper, we also considered whether a wreath product  $S \wr T$ , where  $S$  is an automaton monoid and  $T$  is a finite monoid, was necessarily an automaton monoid. We managed to prove that such a wreath product arises as a *submonoid* of an automaton monoid. In this paper, we obtain a complete answer: all such wreath products arise as automaton monoids (Theorem 5).

We consider whether a Rees matrix semigroup over an automaton semigroup is also an automaton semigroup. We do not have a complete answer, but we prove that this holds under certain restrictions (Proposition 6). This is a step towards classifying completely simple automaton semigroups [4, Open problem 5.8(3)].

We prove that a certain kind of strong semilattice of automaton semigroups is itself an automaton semigroup (Proposition 8). This result is then applied when we turn to the question of whether a small extension of an automaton semigroup is necessarily an automaton semigroup. (Recall that if  $S$  is a semigroup and  $T$  is a subsemigroup of  $S$  with  $S \setminus T$  finite, then  $S$  is a small extension of  $T$  and  $T$  is a large subsemigroup of  $S$ .) Many finiteness properties are known to be preserved on passing to large subsemigroups and small extensions; see the survey [5]. It is already known that a large subsemigroup of an automaton semigroup is not necessarily an automaton semigroup, for  $(\mathbb{N} \cup \{0\}, +)$  is an automaton semigroup but  $(\mathbb{N}, +)$  is not; see [4, Section 5]. We do not have a complete answer, but we prove some special cases in Section 7. The importance of these results is that *if*

the class of automaton semigroups is not closed under forming small extensions, then we have eliminated several standard constructions as potential sources of counterexamples.

In all of the automaton constructions in this paper, we use alphabets of symbols consisting at least partially of tuples of symbols from the automata for the ‘base’ semigroups of the construction. This seems to be quite a powerful approach, as it allows the automaton to have access to a lot of information at each transition.

Finally, we present new examples of semigroups that do not arise as automaton semigroups. This is an important advance, because a major difficulty in studying the class of automaton semigroup is that if a semigroup has the properties that automaton semigroups have generally, such as residual finiteness [4, Proposition 3.2], then there are no general techniques for proving it is not an automaton semigroup. In the pre-existing literature, there is a unique example of a residually finite semigroup that is known not to arise as an automaton semigroup: namely, the free semigroup of rank 1 (or, if one prefers,  $(\mathbb{N}, +)$ ) [4, Proposition 4.3]. We prove that no subsemigroup of this semigroup arises as an automaton semigroup (Theorem 15). Although our proof is specialised, and thus still leaves open the problem of finding a general technique for proving that a semigroup is not an automaton semigroup, we at least now have a countable, rather than singleton, class of non-automaton semigroups.

## 2 Preliminaries

In this section we briefly recall the necessary definitions and concepts required in the rest of the paper. For a fuller introduction to automaton semigroups, see the discussion and examples in [4, Sect. 2].

An *automaton*  $\mathcal{A}$  is formally a triple  $(Q, B, \delta)$ , where  $Q$  is a finite set of *states*,  $B$  is a finite alphabet of *symbols*, and  $\delta$  is a transformation of the set  $Q \times B$ . The automaton  $\mathcal{A}$  is normally viewed as a directed labelled graph with vertex set  $Q$  and an edge from  $q$  to  $r$  labelled by  $x | y$  when  $(q, x)\delta = (r, y)$ :

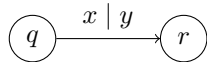

The interpretation of this is that if the automaton  $\mathcal{A}$  is in state  $q$  and reads symbol  $x$ , then it changes to the state  $r$  and outputs the symbol  $y$ . Thus, starting in some state  $q_0$ , the automaton can read a sequence of symbols  $\alpha_1\alpha_2 \dots \alpha_n$  and output a sequence  $\beta_1\beta_2 \dots \beta_n$ , where  $(q_{i-1}, \alpha_i)\delta = (q_i, \beta_i)$  for all  $i = 1, \dots, n$ .

Such automata are more usually known in computer science as deterministic real-time (synchronous) transducers, or Mealy machines. In the field of automaton semigroups and groups, they are simply called ‘automata’ and this

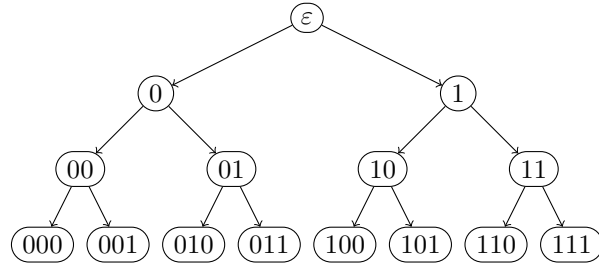

Figure 1: The set  $\{0,1\}^*$  viewed as a rooted binary tree.

paper retains this terminology.

Each state  $q \in Q$  acts on  $B^*$ , the set of finite sequences of elements of  $B$ . The action of  $q \in Q$  on  $B^*$  is defined as follows:  $\alpha \cdot q$  (the result of  $q$  acting on  $\alpha$ ) is defined to be the sequence the automaton outputs when it starts in the state  $q$  and reads the sequence  $\alpha$ . That is, if  $\alpha = \alpha_1\alpha_2 \dots \alpha_n$  (where  $\alpha_i \in B$ ), then  $\alpha \cdot q$  is the sequence  $\beta_1\beta_2 \dots \beta_n$  (where  $\beta_i \in B$ ), where  $(q_{i-1}, \alpha_i)\delta = (q_i, \beta_i)$  for all  $i = 1, \dots, n$ , with  $q_0 = q$ .

The set  $B^*$  can be identified with an ordered regular tree of degree  $|B|$ . The vertices of this tree are labelled by the elements of  $B^*$ . The root vertex is labelled with the empty word  $\varepsilon$ , and a vertex labelled  $\alpha$  (where  $\alpha \in B^*$ ) has  $|B|$  children whose labels are  $\alpha\beta$  for each  $\beta \in B$ . It is convenient not to distinguish between a vertex and its label, and thus one normally refers to ‘the vertex  $\alpha$ ’ rather than ‘the vertex labelled by  $\alpha$ ’. (Figure 1 illustrates the tree corresponding to  $\{0,1\}^*$ .)

The action of a state  $q$  on  $B^*$  can thus be viewed as a transformation of the corresponding tree, sending the vertex  $w$  to the vertex  $w \cdot q$ . Notice that, by the definition of the action of  $q$ , if  $\alpha\alpha' \cdot q = \beta\beta'$  (where  $\alpha, \beta \in B^*$  and  $\alpha', \beta' \in B$ ), then  $\alpha \cdot q = \beta$ . In terms of the transformation on the tree, this says that if one vertex ( $\alpha$ ) is the parent of another ( $\alpha\alpha'$ ), then their images under the action by  $q$  are also parent ( $\beta$ ) and child ( $\beta\beta'$ ) vertices. More concisely, the action of  $q$  on the tree preserves adjacency and is thus an endomorphism of the tree. Furthermore, the action’s preservation of lengths of sequences becomes a preservation of levels in the tree.

The actions of states extends naturally to actions of words:  $w = w_1 \dots w_n$  (where  $w_i \in Q$ ) acts on  $\alpha \in B^*$  by

$$(\dots((\alpha \cdot w_1) \cdot w_2) \dots w_{n-1}) \cdot w_n.$$

So there is a natural homomorphism  $\phi : Q^+ \rightarrow \text{End } B^*$ , where  $\text{End } B^*$  denotes the endomorphism semigroup of the tree  $B^*$ . The image of  $\phi$  in  $\text{End } B^*$ , which is necessarily a semigroup, is denoted  $\Sigma(\mathcal{A})$ .

A semigroup  $S$  is called an *automaton semigroup* if there exists an automaton  $\mathcal{A}$  such that  $S \simeq \Sigma(\mathcal{A})$ .

It is often more convenient to reason about the action of a state or word on a single sequence of infinite length than on sequences of some arbitrary fixed length. The set of infinite sequences over  $B$  is denoted  $B^\omega$ . The infinite sequence consisting of countably many repetitions of the finite word  $\alpha \in B^*$  is denoted  $\alpha^\omega$ . For synchronous automata, the action on infinite sequences determines the action on finite sequences and *vice versa*.

The following lemma summarises the conditions under which two words  $w$  and  $w'$  in  $Q^+$  represent the same element of the automaton semigroup. The results follow immediately from the definitions, but are so fundamental that they deserve explicit statement:

**Lemma 1.** *Let  $w, w' \in Q^+$ . Then the following are equivalent:*

- (i)  $w$  and  $w'$  represent the same element of  $\Sigma(\mathcal{A})$ ;
- (ii)  $w\phi = w'\phi$ ;
- (iii)  $\alpha \cdot w = \alpha \cdot w'$  for each  $\alpha \in B^*$ ;
- (iv)  $w$  and  $w'$  have the same actions on  $B^n$  for every  $n \in \mathbb{N}^0$ ;
- (v)  $w$  and  $w'$  have the same actions on  $B^\omega$ .

Generally, there is no need to make a notational distinction between  $w$  and  $w\phi$ . Thus  $w$  denotes both an element of  $Q^+$  and the image of this word in  $\Sigma(\mathcal{A})$ . In particular, one writes ‘ $w = w'$  in  $\Sigma(\mathcal{A})$ ’ instead of the strictly correct ‘ $w\phi = w'\phi$ ’. With this convention, notice that  $Q$  generates  $\Sigma(\mathcal{A})$ .

Some further notation is required for the rest of the paper: For  $w \in Q^+$ , define  $\tau_w : B \rightarrow B$  by  $b \mapsto b \cdot w$ . For  $b \in B$ , define  $\pi_b : Q \rightarrow Q$  by  $q \mapsto r$  if  $(q, b)\delta = (r, x)$  for some  $x \in B$  (in fact,  $x = b\tau_q$ ). So  $q\pi_b$  is the state to which the edge from  $q$  labelled by  $b \mid \cdot$  leads. Thus  $(q, b)\delta = (q\pi_b, b\tau_q)$ .

Further, let  $w \in Q^+$ . For any  $\alpha \in B^*$ , there is a unique  $w|_\alpha \in \text{End } B^*$  such that  $\alpha\beta \cdot w = (\alpha \cdot w)(\beta \cdot w|_\alpha)$ ; see [18] for details. Notice that  $w, w' \in Q^+$  are equal in  $\Sigma(\mathcal{A})$  if and only if  $w|_\alpha = w'|_\alpha$  for all  $\alpha \in B^*$ .

We now recall the notion of *wreath recursions*. The endomorphism semigroup of  $B^*$  decomposes as a recursive wreath product:

$$\text{End } B^* = \text{End } B^* \wr \mathcal{T}_B,$$

where  $\mathcal{T}_B$  is the transformation semigroup of the set  $B$ . That is,

$$\text{End } B^* = \left( \underbrace{\text{End } B^* \times \dots \times \text{End } B^*}_{|B| \text{ times}} \right) \rtimes \mathcal{T}_B$$

where  $\mathcal{T}_B$  acts from the right on the co-ordinates of elements of the direct product of  $n$  copies of  $\text{End } B^*$ . Hence, if  $p, q \in \text{End } B^*$  with  $p = (x_0, x_1, \dots, x_{n-1})\tau$  and  $q = (y_0, y_1, \dots, y_{n-1})\rho$ , where  $\tau, \rho \in \mathcal{T}_B$  and  $x_i, y_j \in \text{End } B^*$ , then

$$pq = (x_0y_0\tau, x_1y_1\tau, \dots, x_{n-1}y_{n-1}\tau)\tau\rho. \quad (1)$$

If  $p \in \text{End } B^*$  with  $p = (x_0, x_1, \dots, x_{n-1})\tau$ , then  $\tau$  describes the action of  $p$  on  $B$  and each  $x_i$  is an element of  $\text{End } B^*$  whose action on  $B^*$  mirrors the action of  $p$  on the subtree  $b_iB^*$ . Alternatively: to act on  $B^*$  by  $p$ , act on each subtree  $b_iB^*$  by  $x_i$ , and then act on the collection of the resulting subtrees according to  $\tau$ .

If  $p \in Q$ , then  $\tau = \tau_p$  and  $x_i = p\pi_i$ . That is,

$$p = (p\pi_1, p\pi_2, \dots, p\pi_{n-1})\tau_p.$$

This description of the action of  $p$  is called a *wreath recursion*. Its primary use is to calculate, by means of the multiplication given in (1), the action of a word  $w \in Q^+$  on  $B^*$ .

### 3 Free products

The *free product* of two semigroups  $S = \text{sgp}\langle X_1 \mid R_1 \rangle$  and  $T = \text{sgp}\langle X_2 \mid R_2 \rangle$ , denoted  $S \star T$ , is the semigroup with presentation  $\text{sgp}\langle X_1 \cup X_2 \mid R_1 \cup R_2 \rangle$ .

In [3, Conjecture 5], the present authors conjectured that there exist finite semigroups  $S$  and  $T$  such that  $S \star T$  is not an automaton semigroup. We begin by showing that this is not the case.

**Theorem 2.** *Let  $S$  and  $T$  be finite semigroups. Then  $S \star T$  is an automaton semigroup.*

*Proof.* Let  $e$  and  $f$  be distinguished idempotents of  $S$  and  $T$  respectively. Let  $\mathcal{A} = (Q, C, \delta)$  with  $Q = Q_1 \cup Q_2$ , where  $Q_1$  is a copy of  $S$  and  $Q_2$  is a copy of  $T$ . Define an alphabet

$$B = \{ \boxed{\phantom{a}}, \boxed{s}, \boxed{st}, \boxed{st}^\circ, \circledast, \circledast, \circledast, \circledast^\circ \mid s \in S, t \in T \}$$

and let  $\delta$  be the transformation of  $Q \times B$  given by the following transition table.

	$s$	$t$
$\square\square$	$(f, \boxed{s\square})$	$(f, \boxed{\square\square})$
$\boxed{a}\square$	$(f, \boxed{as\square})$	$(f, \boxed{a\square t})$
$\boxed{a}\boxed{b}$	$(s, \boxed{a\square b}^\circ)$	$(f, \boxed{a\square bt})$
$\boxed{a}\boxed{b}^\circ$	$(s, \boxed{a\square b}^\circ)$	$(t, \boxed{a\square b}^\circ)$
$\circledast\square$	$(e, \circledast\square)$	$(e, \circledast t)$
$\circledast\boxed{b}$	$(e, \circledast\boxed{b\square s})$	$(e, \circledast\boxed{bt\square})$
$\circledast\boxed{b}\boxed{a}$	$(e, \circledast\boxed{bas})$	$(t, \circledast\boxed{b\square a}^\circ)$
$\circledast\boxed{b}\boxed{a}^\circ$	$(s, \circledast\boxed{b\square a}^\circ)$	$(t, \circledast\boxed{b\square a}^\circ)$

for  $s \in Q_1$ ,  $t \in Q_2$ ,  $a \in S$  and  $b \in T$ , where  $as$  and  $bt$  denote elements of  $S$  and  $T$  respectively rather than two-letter words.

We will refer to  $\square\square$ -symbols and  $\circledast$ -symbols, meaning all symbols having those shapes. Actions on strings of  $\square\square$ -symbols will help us distinguish words beginning with an element of  $S$ , while actions on strings of  $\circledast$ -symbols help us distinguish words beginning with an element of  $T$ . We call a symbol *full* if it has entries in both boxes, *open* if not, and *marked* if it has the  $^\circ$  superscript. Notice that all states ‘ignore’ marked symbols: that is, if  $x^\circ$  is a marked symbol, then  $(q, x)\delta = (q, x)$  for all  $q \in Q$ .

We begin by showing that  $\mathcal{A}$  defines actions of  $S$  and  $T$ , and hence of  $S \star T$ , on  $B^*$ . Firstly, we consider only the states  $e$  and  $f$ , whose actions are illustrated in Figure 2. These states are of particular significance, as it can be seen from the definition of  $\delta$  that all transitions lead either back to the state they started from or to one of  $e$  or  $f$ .

The state  $e$  has no effect on marked symbols or the symbol  $\circledast$ , marks any full  $\square\square$ -symbol, and multiplies the second entry of non-empty  $\circledast$ -symbols by  $e$  (or inserts  $e$  if it is blank) – returning to state  $e$  on all of these actions – while on open  $\square\square$ -symbols it multiplies the first entry by  $e$  (or inserts  $e$  if it is blank) and moves to  $f$ . The action of  $f$  can be described by switching the roles of  $e$  and  $f$  and of  $\square\square$ -symbols and  $\circledast$ -symbols in the preceding sentence.

Let  $B_e = B \setminus \{\square\square, \boxed{a\square} : a \in S\}$  and  $B_f = B \setminus \{\circledast, \circledast\boxed{b} : b \in T\}$ . The above discussion and the fact that  $e$  and  $f$  are idempotents in  $S$  and  $T$  respectively implies that  $e$  and  $f$  act as idempotents on  $B_e^*$  and  $B_f^*$  respectively. To see how  $e$  acts on a string in  $B^*$ , the important symbols to take note of are the  $\square\square$ -symbol with empty second component, then the next  $\circledast$ -symbol with empty second component, and so on alternatingly, since these are the symbols that will cause the automaton to change state. So we write each string as a prefix of some alternating product of strings in  $B_e$  and  $B_f$ , distinguishing the

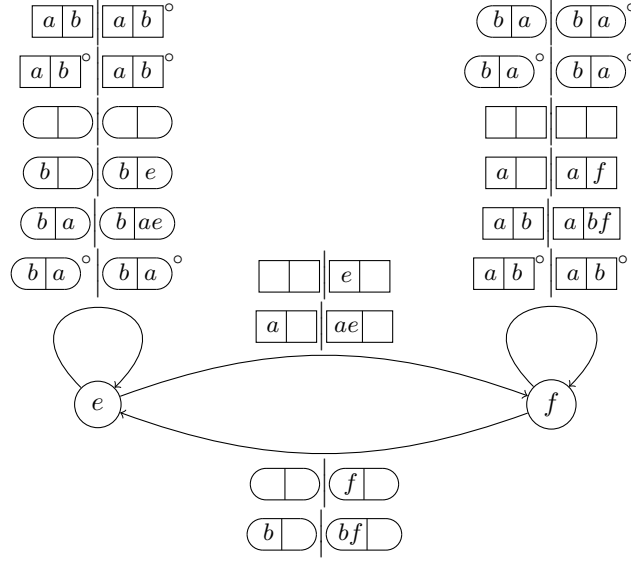

Figure 2: Actions of  $e$  and  $f$ .

important symbols, as follows (where  $a_i$  or  $b_i$  may denote empty space):

$$\alpha_1 \boxed{a_1} \beta_1 \textcircled{b_1} \dots \alpha_i \boxed{a_i} \beta_i \textcircled{b_i} \dots \in B^\omega,$$

where  $\alpha_i \in B_e^*$  and  $\beta_i \in B_f^*$ . Then

$$\begin{aligned} & \alpha_1 \boxed{a_1} \beta_1 \textcircled{b_1} \dots \alpha_i \boxed{a_i} \beta_i \textcircled{b_i} \dots \cdot e \\ = & (\alpha_1 \cdot e) \boxed{a_1 e} (\beta_1 \cdot f) \textcircled{b_1 f} \dots (\alpha_i \cdot e) \boxed{a_i e} (\beta_i \cdot f) \textcircled{b_i f} \dots \end{aligned}$$

(If, for example,  $a_i$  denotes an empty space, then  $a_i e = e$ .) Acting on the resulting string by  $e$  again has the result of replacing each  $e$  and  $f$  by  $e^2$  and  $f^2$  respectively, but since we already know that  $e$  acts idempotently on  $S$  and  $B_e^*$ , while  $f$  acts idempotently on  $T$  and  $B_f^*$ , this makes no change. Hence  $e^2 = e$  in  $\Sigma(\mathcal{A})$ . Similarly, to show that  $f^2 = f$  in  $\Sigma(\mathcal{A})$ , we would express strings in  $B^*$  in the form  $\beta_1 \textcircled{b_1} \alpha_1 \boxed{a_1} \dots$

We can now describe the action of  $Q_1$  on  $B^*$ . Each state in  $Q_1$  recurses to itself on marked symbols (which it leaves unchanged) and on full  $\square\square$ -symbols (which it marks); to  $e$  on unmarked  $\sqsupset$ -symbols; and to  $f$  on open  $\square\square$ -symbols. Let  $C$  be the set of marked symbols and full  $\square\square$ -symbols in  $B$ , and for  $\alpha \in C^*$ , let  $\alpha^\circ$  denote the word obtained from  $\alpha$  by marking all unmarked symbols. We can express any string in  $B^*$  in the form  $\alpha\beta\gamma$ , where  $\alpha \in C^*$ ,  $\beta \in B \setminus C$ ,  $\gamma \in B^*$ . Let  $s_1, \dots, s_n \in S$ . Since the type ( $\square\square$  or  $\sqsupset$ ) of the symbol  $\beta$  is not changed by the action of any state, and also  $\beta \cdot s \notin C$  for any  $s \in S$ , we have for some



$\epsilon \in \{e, f\}$

$$\begin{aligned}\alpha\beta\gamma \cdot s_1 \dots s_k &= [\alpha^\circ(\beta \cdot s_1)(\gamma \cdot \epsilon)] \cdot s_2 \dots s_n \\ &= \dots = \alpha^\circ(\beta \cdot s_1 \dots s_n)(\gamma \cdot \epsilon^n) \\ &= \alpha^\circ(\beta \cdot s_1 \dots s_n)(\gamma \cdot \epsilon),\end{aligned}$$

Thus the action of  $\langle Q_1 \rangle$  on  $B^*$  depends only on its action on  $B \setminus C$ . (Note that the idempotency of  $e$  and  $f$  is critical in establishing this.) Let  $w = s_1 \dots s_n \in Q_1^+$  and let  $s_w$  be the element of  $S$  represented by  $w$ . Then

$$\begin{aligned}\square\square \cdot w &= \boxed{s_w}\square \\ \boxed{a}\square \cdot w &= \boxed{as_w}\square \\ \square\square \cdot w &= \square\square \\ \boxed{b}\square \cdot w &= \boxed{bs_w} \\ \boxed{b}\boxed{a} \cdot w &= \boxed{bas_w}.\end{aligned}$$

This shows that the action of  $w$  on  $B^*$  depends only on  $s_w \in S$ , so that  $\langle Q_1 \rangle$  must be isomorphic to some quotient of  $S$ .

By symmetry of the construction, we also find that  $\langle Q_2 \rangle$  is isomorphic to some quotient of  $T$ , and so  $\mathcal{A}$  defines an action of  $S \star T$  on  $B^*$ .

It remains to prove that this action is faithful. We have already seen that the actions of words in  $Q_1^+$  and  $Q_2^+$  depend only on the elements of  $S$  and  $T$  respectively that they represent, so it suffices to consider the action of reduced words. The idea of this automaton is that the action on the string  $\square\square^\omega$  can be used to recover any reduced word in  $S \star T$  starting with an element of  $S$ , while  $\square\square^\omega$  is used to recover reduced words starting with elements of  $T$ . Given a word  $s_1 t_1 \dots s_k t_k$  with  $s_i \in S$ ,  $t_i \in T$ , we have

$$\begin{aligned}\square\square^\omega \cdot s_1 t_1 \dots s_k t_k &= \boxed{s_1}\square\square^\omega \cdot t_1 s_2 \dots s_k t_k \\ &= \boxed{s_1 t_1}\square\square^\omega \cdot s_2 t_2 \dots s_k t_k \\ &= \boxed{s_1 t_1}^\circ \boxed{s_2 t_2}\square\square^\omega \cdot s_3 t_3 \dots s_k t_k \\ &= \boxed{s_1 t_1}^\circ \boxed{s_2 t_2}^\circ \dots \boxed{s_{k-1} t_{k-1}}^\circ \boxed{s_k t_k}.\end{aligned}$$

If the final  $t_k$  is not present, the resulting final symbol will instead be  $\boxed{s_k}\square$ . Thus we can read off any reduced word  $w$  starting with an element from  $S$  from the string  $\square\square^\omega \cdot w$ . Similarly, if  $w$  is a reduced word starting with an element from  $T$ , we can read it off from the string  $\square\square^\omega \cdot w$ . Meanwhile,

$$\begin{aligned}\square\square^\omega \cdot t_1 s_1 \dots t_k s_k &= \boxed{s_1 t_2}^\circ \dots \boxed{s_{k-1} t_k}^\circ \boxed{s_k}\square, \\ \square\square^\omega \cdot s_1 t_1 \dots s_k t_k &= \boxed{t_1 s_1}^\circ \dots \boxed{t_{k-1} s_k}^\circ \boxed{t_k}\square.\end{aligned}$$

Hence pairs of distinct elements of  $S \star T$  can be distinguished by their actions on one of  $\square\square^\omega$  or  $\square\square^\omega$ , and so  $\Sigma(\mathcal{A}) \cong S \star T$ .  $\square$

We can in fact considerably generalise the above construction: the important point is the existence of idempotents in the factor semigroups. The following theorem generalises [3, Theorem 2], which says that the free product of automaton semigroups  $S$  and  $T$  is an automaton semigroup if  $S$  and  $T$  each contain a left identity.

**Theorem 3.** *Let  $S$  and  $T$  be automaton semigroups each containing at least one idempotent. Then  $S \star T$  is an automaton semigroup.*

This is immediate from the following more technical theorem.

**Theorem 4.** *Let  $S_1$  and  $S_2$  be automaton semigroups and suppose that there exist  $e_i \in S_i$  such that if  $w =_{S_i} w'$ , then  $e_i^{|w|} = e_i^{|w'|}$  for  $i = 1, 2$ . Then  $S_1 \star S_2$  is an automaton semigroup.*

*Proof.* Let  $e$  and  $f$  be distinguished elements of  $S$  and  $T$  respectively satisfying the hypothesis of the theorem. (For example,  $e$  and  $f$  might be idempotents.) Let  $\mathcal{A}_1 = (Q_1, A, \delta_1)$  and  $\mathcal{A}_2 = (Q_2, B, \delta_2)$  be automata for  $S$  and  $T$  respectively. We may assume that  $e \in Q_1$  and  $f \in Q_2$ . Let  $X = \{\overline{a|b}, \overline{b|a} \mid a \in A, b \in B\}$  and  $Y = \{\$, \#\}$ . We shall call the symbols in  $X$  *dominoes* and the symbols in  $Y$  *gates*. We construct an automaton  $\mathcal{A} = (Q, C, \delta)$  with  $Q = Q_1 \cup Q_2$ ,

$$C = \{x, x^S, x^T, x^\circ, y, \hat{y}, \bar{y} \mid x \in X, y \in Y\}$$

and  $\delta$  the transformation of  $Q \times C$  defined as follows. For  $s \in Q_1, t \in Q_2, a \in A, b \in B$  suppose that  $(s, a)\delta_1 = (s_0, a_0)$  and  $(t, b)\delta_2 = (t_0, b_0)$ . Then the action of  $Q$  on  $\square\square$ -symbols and  $\$$ -gates is given by

	$s$	$t$
$\overline{a b}$	$(s_0, \overline{a_0 b}^S)$	$(t, \overline{a b})$
$\overline{a b}^S$	$(s_0, \overline{a_0 b}^S)$	$(t_0, \overline{a b_0}^T)$
$\overline{a b}^T$	$(s, \overline{a b}^\circ)$	$(t_0, \overline{a b_0}^T)$
$\overline{a b}^\circ$	$(s, \overline{a b}^\circ)$	$(t, \overline{a b}^\circ)$
$\bar{\$}$	$(f, \$)$	$(f, \$)$
$\hat{\$}$	$(s, \$)$	$(f, \hat{\$})$
$\$$	$(s, \$)$	$(t, \$)$

The action of  $Q$  on the remainder of  $C$  ( $\square$ -symbols and  $\#$ -gates) is given by replacing each  $\overline{i|j}$  in the above table by  $\overline{j|i}$  and swapping the corresponding symbols in the tuples  $(S, s, s_0, f, \$)$  and  $(T, t, t_0, e, \#)$ .

For  $x \in X$  and  $y \in Y$ , we call  $x$  *unmarked*,  $x^S$  *S-marked*,  $x^T$  *T-marked*,  $x^\circ$  *circled*,  $y$  *open*,  $\hat{y}$  *half-open* and  $\bar{y}$  *closed*.

This construction is inspired by the construction in Theorem 2. Since single symbols are no longer sufficient for distinguishing elements of  $S$  and of  $T$ , we instead use strings of several  $\square\square$ - or  $\circlearrowleft$ -symbols, separated by either  $\$$ -gates or  $\#$ -gates.

We first describe the action of a word in  $Q_1Q^+$  on a string consisting only of unmarked  $\square\square$ -symbols and closed  $\$$ -gates. Let  $w = u_1v_1 \dots u_kv_k$  with  $u_i \in Q_1^+$  and  $v_i \in Q_2^+$  and let  $\alpha = \alpha_1\overline{\$}\alpha_2 \dots \overline{\$}\alpha_k$  with each  $\alpha_i$  consisting only of unmarked  $\square\square$ -symbols (note that  $\alpha_i$  may be empty). Then  $u_1$  acts on  $\alpha$  by acting on the first entries of  $\alpha_1$  just as in  $\mathcal{A}_1$ ,  $S$ -marking the resulting  $\square\square$ -symbols and leaving the rest of the string unchanged. Next,  $v_1$  acts on  $\alpha \cdot u_1$  by acting on the second entries of  $\alpha_1 \cdot u_1$  just as in  $\mathcal{A}_2$ ,  $T$ -marking the resulting  $\square\square$ -symbols, half-opening the first  $\$$ -gate, and leaving the rest of the string unchanged. Now  $\alpha \cdot u_1v_1$  begins with a string of  $T$ -marked  $\square\square$ -symbols, followed by a half-open  $\$$ -gate. The first state in  $u_2$  circles the initial string of  $\square\square$ -symbols and opens the  $\$$ -gate, all the while not changing state. By induction, we have

$$\alpha \cdot w = (\alpha_1 \cdot u_1v_1)^\circ \overline{\$}(\alpha_2 \cdot u_2v_2)^\circ \overline{\$} \dots \overline{\$}(\alpha_k \cdot u_kv_k).$$

(All dominoes up until the last  $\$$ -gate are circled.) Thus if  $w' = u'_1v'_1 \dots u'_kv'_k$  is another word with  $u'_i \in Q_1^+$  and  $v'_i \in Q_2^+$  and some  $u'_i \neq_S u_i$ , we can distinguish  $w$  and  $w'$  as follows. Let  $\gamma = \overline{\$}^{i-1}\beta$ , where  $\beta$  is some string of  $\square\square$ -symbols such that reading off the first entries of  $\beta$  gives a word which  $u_i$  and  $u'_i$  act differently on. Then

$$\gamma \cdot w = \overline{\$}^{i-1}(\beta \cdot u_i)^\circ \neq \overline{\$}^{i-1}(\beta \cdot u'_i)^\circ = \gamma \cdot w'.$$

If instead some  $v_i \neq_T v'_i$ , then the same idea using second entries instead of first entries for  $\beta$  works. Words in  $Q_1Q^+$  representing elements of  $S \star T$  of different reduced lengths can be distinguished by their actions on the string  $\overline{\$}^\omega$ . (The *reduced length* of an element  $s \in S \star T$  is the length of an alternating product of elements of  $S$  and  $T$  representing  $s$ .)

Words in  $Q_2Q^+$  have an analogous action to the one described above on strings consisting only of unmarked  $\circlearrowleft$ -symbols and closed  $\#$ -gates, and can thus be distinguished similarly. Two words not starting with symbols from the same  $Q_i$  can be distinguished their actions on either  $\overline{\$}^\omega$  or  $\overline{\#}^\omega$  (usually both).

It remains to show that  $\mathcal{A}$  defines an action of  $S \star T$  on  $C^*$ . For this, it suffices to show that the action of  $Q_1^+$  gives an action of  $S$ , since it will follow by symmetry of the construction that the action of  $Q_2^+$  gives an action of  $T$ .

Let  $w \in Q_1^+$  and  $\alpha \in C^*$ . For clarity, we explain the action of  $w$  on  $\alpha$  by a series of observations.

- (i) When acting on  $C^*$  by  $Q_1^+$ , certain symbols are ‘uninteresting’, in the sense that the same thing happens to them when acted on by any word in  $Q_1^+$ , and they also do not affect what happens to the rest of the string

containing them. All circled symbols are uninteresting, as are  $\$, \hat{\$}, \#, \hat{\#}$ , unmarked  $\square$ -symbols and  $T$ -marked  $\square$ -symbols. We may thus assume that  $\alpha$  contains none of these symbols; that is, that

$$\alpha \in \{\bar{\$}, \bar{\#}, \hat{\#}, \boxed{ab}, \boxed{ab}^S, \circled{ab}^T, \circled{ab}^S \mid a \in A, b \in B\}^*.$$

- (ii) Furthermore, under actions of  $Q_1^+$ , the following pairs of symbols are essentially the same:  $(\bar{\#}, \hat{\#}), (\boxed{ab}, \boxed{ab}^S)$  and  $(\circled{ba}^T, \circled{ba}^S)$ . This is because the action of  $Q_1$  on the two symbols in each pair is identical. In each case, the output from both symbols is a symbol of the second type, and the symbols of the first type do not occur in  $C^* \cdot Q_1^+$ . We may thus assume that

$$\alpha \in \{\bar{\$}, \hat{\#}, \boxed{ab}^S, \circled{ba}^S \mid a \in A, b \in B\}^*.$$

- (iii) For  $\beta$  consisting only of  $S$ -marked dominoes, then let  $\beta_A \in A^*$  be the word obtained from  $\beta$  by reading off the symbols from  $A$  in each domino (which will be the first entry for  $\square$ -symbols and the second entry for  $\square$ -symbols). Then  $(\beta \cdot w)_A = \beta_A \cdot w$ , where the action of  $w$  is in  $\mathcal{A}$  on the left-hand side and in  $\mathcal{A}_1$  on the right-hand side. If we define  $\beta_B$  similarly, then  $(\beta \cdot w)_B = \beta_B$ . Hence  $Q_1^+$  defines an action of  $S$  on  $S$ -marked dominoes.

Moreover, note that for  $v \in Q_2^+$  we have  $(\beta \cdot v)_A = \beta_A$  and  $(\beta \cdot v)_B = \beta_B \cdot v$ .

- (iv) In general,  $\alpha$  can be assumed to be a prefix of some  $\gamma = \alpha_1 y_1 \alpha_2 y_2 \dots \alpha_k y_k$ , where each  $\alpha_i$  is a string of  $S$ -marked dominoes and each  $y_i$  is a gate. If  $w$  has length  $n$ , then

$$\gamma \cdot w = (\alpha_1 \cdot w) y_1 (\alpha_2 \cdot g_2^n) y_2 \dots (\alpha_k \cdot g_k^n),$$

where  $g_i$  is  $e$  if  $y_{i-1} = \hat{\#}$  and  $f$  if  $y_{i-1} = \bar{\$}$ . By (iii) and the hypothesis on  $e$  and  $f$ , the string  $\alpha_1 \cdot w$  and each  $\alpha_i \cdot g_i^n$  depend only on the element of  $S$  represented by  $w$ . Hence we have  $\alpha \cdot w = \alpha \cdot w'$  whenever  $w =_S w'$ , for  $w, w' \in Q_1^+$  and  $\alpha \in C^*$ .

Thus  $\mathcal{A}$  defines a faithful action of  $S \star T$  on  $C^*$  and so  $S \star T$  is an automaton semigroup.  $\square$

Aside from  $S$  and  $T$  containing idempotents, another way to satisfy the hypothesis of Theorem 4 is for  $S$  and  $T$  to be *homogeneous*, meaning that any two words representing the same element have the same length. (In this case  $e$  and  $f$  can be taken to be arbitrary elements of  $S$  and  $T$  respectively.) Free semigroups and free commutative semigroups of course have this property. A less trivial example is the plactic monoid (see, for example, [15, Ch. 5], which Picantin has recently shown to be an automaton semigroup [19].

The question of whether the class of automaton semigroups is closed under taking free products remains open. It is even possible that the condition in Theorem 4 is necessary. Unlike [3, Theorem 2], Theorem 4 does account (by induction) for the free semigroups and free monoids that can be constructed as free products of automaton semigroups (i.e. free semigroups of rank at least 4 and free monoids of rank at least 2).

## 4 Wreath products

The wreath product of two automaton semigroups is certainly not always an automaton semigroup, since it need not even be finitely generated. One way to ensure that a wreath product  $S \wr T$  is finitely generated is to require  $S$  and  $T$  to be monoids, with  $T$  finite. For monoids  $S$  and  $T$  with  $T = \{t_1, \dots, t_n\}$  finite, the *wreath product*  $S \wr T$  of  $S$  with  $T$  is a semidirect product  $S^{|T|} \rtimes T$ , where  $T$  acts on elements of  $S^{|T|}$  by  $(s_{t_1}, s_{t_2}, \dots, s_{t_n})^t = (s_{t_1 t}, s_{t_2 t}, \dots, s_{t_n t})$ .

It turns out, contrary to [3, Conjecture 6], that the wreath product of an automaton monoid and a finite monoid is always an automaton monoid.

**Theorem 5.** *Let  $S$  be an automaton monoid and  $T$  a finite monoid. Then  $S \wr T$  is an automaton monoid.*

*Proof.* First observe that  $S^{|T|}$  (the direct product of  $|T|$  copies of  $S$ ) is an automaton semigroup by [4, Proposition 5.5], and let  $\mathcal{A} = (Q, A, \delta)$  be the standard automaton for  $S^{|T|}$ , which has  $Q = P^{|T|}$  (the Cartesian product of  $|T|$  copies of  $P$ ) for some generating set  $P$  of  $S$ .

We construct an automaton  $\mathcal{B} = (Q', C, \delta')$  with  $\Sigma(\mathcal{B}) = S \wr T$ . Let  $Q' = Q \times T$ ,  $C = A \times B$ , where  $B$  is a copy of  $T$ , and let  $\delta' : Q' \times C \rightarrow Q' \times C$  be given by:

$$((s, t), (a, b)) \mapsto ((s^b \pi_a, 1_T), (a \tau_{s^b}, bt)),$$

for  $s \in Q$ ,  $t \in T$ ,  $a \in A$ ,  $b \in B$ , and  $\pi_a, \tau_{s^b}$  are as in  $\mathcal{A}$ . Note that after reading the first symbol in any  $\alpha \in C^*$ , the automaton  $\mathcal{B}$  only utilises the states of the form  $(s, 1_T)$ , which act like  $s$  on the first component of symbols in  $C$  and leave the second components unchanged. (See the example in Figure 3.)

The ‘ideal’ strings in  $C^*$ , which we use to distinguish elements of  $S \wr T$ , are those from  $D = (A \times T)(A \times \{1_T\})^*$ . For strings in  $D$ , we will simplify the notation by writing  $(a_1, b_1)(a_2, 1_T) \dots (a_n, 1_T)$  as  $(a_1 a_2 \dots a_n, b_1)$ . We have

$$\begin{aligned} (\alpha, 1_T) \cdot (s_1, t_1)(s_2, t_2) \dots (s_m, t_m) &= (\alpha \cdot s_1, t_1) \cdot (s_2, t_2) \dots (s_m, t_m) \\ &= (\alpha \cdot s_1 s_2^{t_1}, t_1 t_2) \cdot (s_3, t_3) \dots (s_m, t_m) \\ &= (\alpha \cdot s_1 s_2^{t_1} s_3^{t_1 t_2} \dots s_m^{t_1 t_2 \dots t_m}, t_1 t_2 \dots t_m). \end{aligned}$$

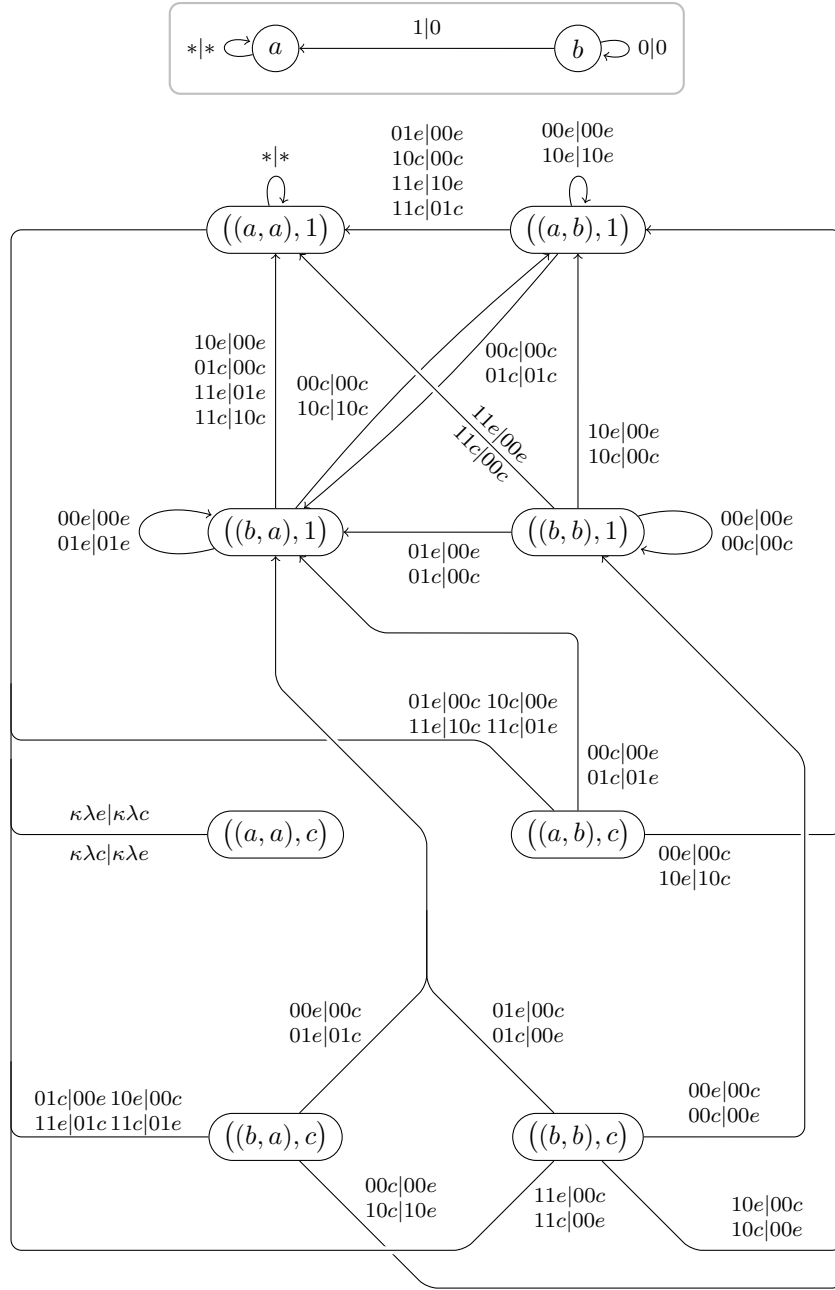

Figure 3: Automaton for the wreath product  $\mathbb{N}_0 \wr C_2$ , where  $C_2$  is the cyclic group of order 2, with element set  $\{e, c\}$ . For reasons of space, symbols  $((\kappa, \lambda), \mu)$  are abbreviated  $\kappa\lambda\mu$ ; thus  $((1, 0), c)$  is shown as  $10c$ . At the top of the diagram, in the grey box, is the original automaton for  $\mathbb{N}_0$ .

Since we already know that  $\mathcal{A}$  gives a faithful action of  $S^{|T|}$  on  $A^*$ , this shows that  $\mathcal{B}$  gives a faithful action of  $S \wr T$  on  $D^*$ . (Acting on  $(\alpha, b)$  with  $b \neq 1_T$  simply has the effect of premultiplying all the elements from  $T$  by  $b$ .) Hence any two words in  $(Q')^*$  representing different elements of  $S \wr T$  can be distinguished by their actions on some word in  $D \subset C^*$ .

It is less obvious that  $\mathcal{B}$  defines an action of  $S \wr T$  on the remainder of  $C^*$ . To see that it does, we view words in  $C^*$  as a concatenation of words in  $D$ , and then for  $w \in (Q')^+$  we have:

$$\begin{aligned} & (\alpha_1, b_1)(\alpha_2, b_2) \dots (\alpha_k, b_k) \cdot w \\ &= [(\alpha_1, b_1) \cdot w] [(\alpha_2, b_2) \cdot (w_2, 1_T)] \dots [(\alpha_k, b_k) \cdot (w_k, 1_T)] \end{aligned}$$

for some elements  $w_j \in S$ . But  $w_2$  is determined uniquely by  $(\alpha_1, b_1)$  and the *element* of  $S \wr T$  represented by  $w$ , and then each  $w_j$  is determined recursively by all the  $(\alpha_i, b_i)$  and  $w_i$  for  $i < j$  (setting  $w_0 = w$ ), so that ultimately all the  $w_j$  are determined uniquely by the string  $(\alpha_1, b_1) \dots (\alpha_k, b_k)$  and the element represented by  $w$ . Hence  $\mathcal{B}$  does indeed define an action of  $S \wr T$  on  $C^*$ , and so  $S \wr T = \Sigma(\mathcal{B})$ .  $\square$

## 5 Rees matrix semigroups

Let us recall the definition of a Rees matrix semigroup. Let  $M$  be a monoid, let  $I$  and  $\Lambda$  be abstract index sets, and let  $P \in \text{Mat}_{\Lambda \times I}(M)$  (that is,  $P$  is a  $\Lambda \times I$  matrix with entries from  $M$ ). Denote the  $(\lambda, i)$ -th entry of  $P$  by  $p_{\lambda i}$ . The *Rees matrix semigroup* over  $M$  with sandwich matrix  $P$ , denoted  $\mathcal{M}[M; I, \Lambda; P]$ , is the set  $I \times M \times \Lambda$  with multiplication defined by

$$(i, x, \lambda)(j, y, \mu) = (i, xp_{\lambda j}y, \mu).$$

The Rees matrix semigroup construction is particularly important because it arises in the classification of completely simple semigroups; see [12, Sect. 3.2–3.3] for background reading.

**Proposition 6.** *Let  $S$  be a Rees matrix semigroup  $\mathcal{M}[M; I, \Lambda; P]$  with  $I$  and  $\Lambda$  finite and  $M$  an automaton monoid. and  $P \in \text{Mat}_{\Lambda \times I}(M)$  a matrix containing the identity element of  $M$  in some position. If there exists an automaton for  $M$  with state set  $Q$  such that  $1_M \in Q$  and  $Q$  is closed under left-multiplication by each non-zero entry of the matrix  $P$ , then  $S$  is an automaton monoid.*

[Note that if  $P$  consists only of ones and zeros, then the hypothesis on  $Q$  is always satisfied.]

*Proof.* Let  $\mathcal{A} = (Q, A, \delta)$  be an automaton with  $\Sigma(\mathcal{B}) = M$ . We may assume that  $Q$  satisfies the hypothesis of the theorem. The fact that  $1_M$  is in  $Q$  and

also appears in the matrix  $P$  ensures that  $S = \mathcal{M}[M; I, \Lambda; P]$  is generated by the finite set  $Q' = I \times Q \times \Lambda$ . Let  $I = \{1, \dots, k\}$  and  $\Lambda = \{1, \dots, l\}$ . Let  $P = (p_{\lambda i})$ .

We construct an automaton  $\mathcal{B}$  with  $\Sigma(\mathcal{B}) = S$ . Let  $\mathcal{B} = (Q', B, \delta')$  with  $B = A \cup C$ , where  $C = ((I \cup \{e\}) \times \Lambda)$  and  $\delta'$  the transformation of  $Q' \times B$  given by

$$\begin{aligned} ((j, x, \mu), (e, \lambda)) &\mapsto ((1, x, 1), (j, \mu)) \\ ((j, x, \mu), (i, \lambda)) &\mapsto ((1, p_{\lambda j}x, 1), (i, \mu)) \\ ((j, x, \mu), a) &\mapsto ((1, x\pi_a, 1), a\tau_x) \end{aligned}$$

for  $x \in Q$ ,  $i \in I$ ,  $j \in I$ ,  $\lambda, \mu \in \Lambda$  and  $a \in A$ , and  $\pi_b, \tau_x$  as in  $\mathcal{B}$ .

This construction somewhat resembles the automaton for the wreath product, in that it is designed to perform the appropriate ‘twist’ to the action of  $M$ . The ‘ideal’ strings, which we use to distinguish elements of  $S$ , are those in  $D = (\{e\} \times \Lambda)A^*$ . For  $(j_i, x_i, \mu_i) \in (Q')^*$ , let  $(j, x, \mu)$  be the element of  $S$  represented by  $(j_1, x_1, \mu_1) \dots (j_k, x_k, \mu_k)$ . For  $(e, \lambda)\alpha \in D$  we have

$$\begin{aligned} &(e, \lambda)\alpha \cdot (j_1, x_1, \mu_1) \dots (j_k, x_k, \mu_k) \\ &= [(j_1, \mu_1)(\alpha \cdot x_1)] \cdot (j_2, x_2, \mu_2) \dots (j_k, x_k, \mu_k) \\ &= [(j_1, \mu_2)(\alpha \cdot x_1 p_{\mu_1 \lambda_2} x_2)] \cdot (j_3, x_3, \mu_3) \dots (j_k, x_k, \mu_k) \\ &= (j_1, \mu_k)(\alpha \cdot x_1 p_{\mu_1 \lambda_2} x_2 \dots p_{\mu_{k-1} \lambda_k} x_k) \\ &= (j, \mu)(\alpha \cdot x). \end{aligned}$$

Thus  $\mathcal{B}$  defines a faithful action of  $S$  on  $D$ .

It is then easy to see that this action extends to an action on the whole of  $B^*$ . We can write any string in  $B^*$  as an alternating product of strings in  $A^*$  and  $C^*$ . Let  $w \in (Q')^*$  with  $w =_S (j, x, \mu) \in Q'$ . When  $w$  acts on  $\alpha \in A^*$ , the output string is  $\alpha \cdot x$  and the automaton ends in state  $(1, x|_{\alpha}, 1)$ , while when  $w$  acts on  $(i_1, \lambda_1) \dots (i_k, \lambda_k) \cdot (j, x, \mu)$ , the output string is  $(i_1 \cdot j, \mu)(i_2, 1) \dots (i_k \cdot j, 1)$  (where  $I \cup \{e\}$  is treated as a left zero semigroup with adjoined identity  $e$ ) and the automaton ends in state  $p_{\lambda_1 j} p_{\lambda_2 1} \dots p_{\lambda_k 1} x$ . Since these end states and outputs depend only on  $(j, x, \mu)$  and the input string, we conclude that  $\mathcal{A}$  defines an action of  $S$  on alternating products of strings in  $A^*$  and  $C^*$ , that is, on  $B^*$ . Moreover, this action is faithful, since elements can be distinguished by their actions on  $D$ . Hence  $\Sigma(\mathcal{A}) \cong S$ .  $\square$

## 6 Strong semilattices of semigroups

We recall the definition of strong semilattices of semigroups here, and refer the reader to [12, Sect. 4.1] for further background reading:



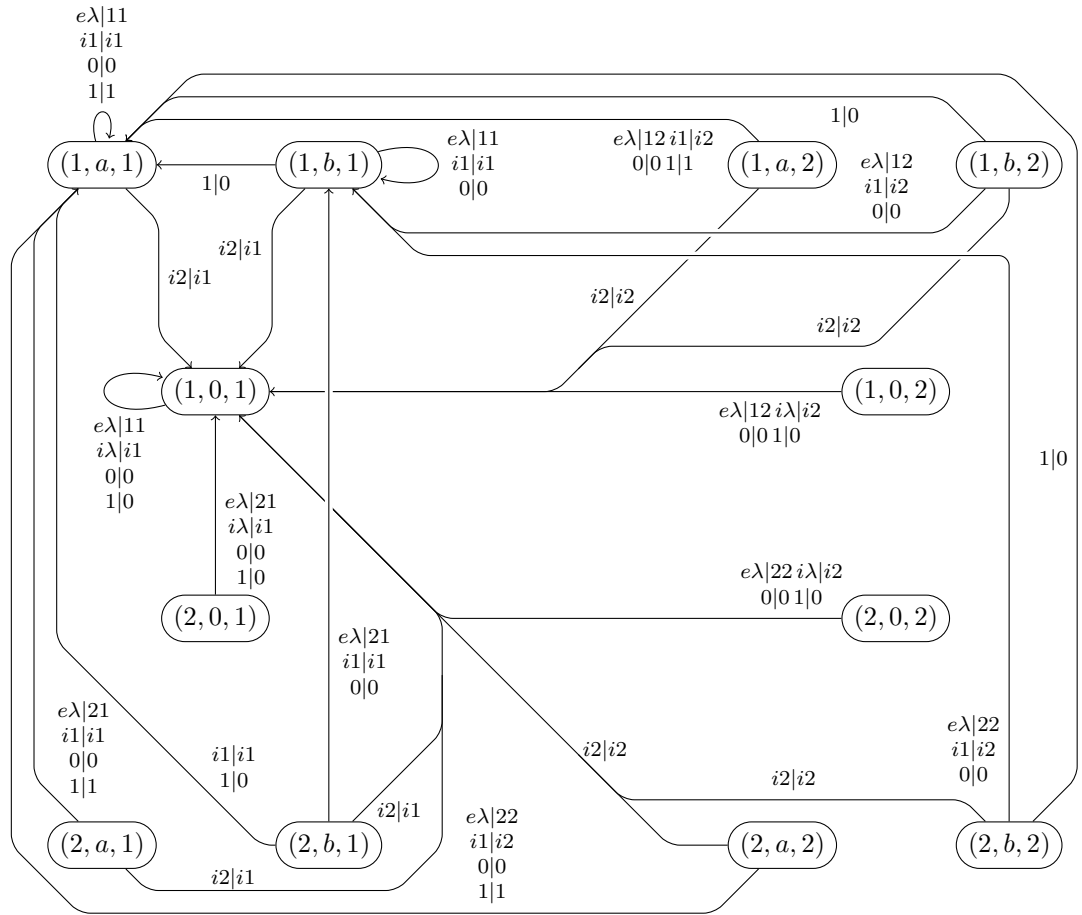
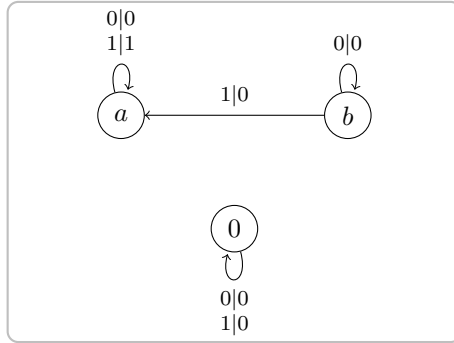

Figure 4: Above, the automaton for semigroup  $F^0$ , where  $F$  is the free monoid generated by  $b$ , and with identity  $a$ . Below, the automaton for  $\mathcal{M}[I, F^0, \Lambda, P]$ , where  $I = \Lambda = \{1, 2\}$  and  $P = \begin{bmatrix} a & a \\ 0 & 0 \end{bmatrix}$ .

**Definition 7.** Let  $Y$  be a semilattice. Recall that the meet of  $\alpha, \beta \in Y$  is denoted  $\alpha \wedge \beta$ . For each  $\alpha \in Y$ , let  $S_\alpha$  be a semigroup. For  $\alpha \geq \beta$ , let  $\phi_{\alpha, \beta} : S_\alpha \rightarrow S_\beta$  be a homomorphism such that

- (i) For each  $\alpha \in Y$ , the homomorphism  $\phi_{\alpha, \alpha}$  is the identity mapping.
- (ii) For all  $\alpha, \beta, \gamma \in Y$  with  $\alpha \geq \beta \geq \gamma$ ,

$$\phi_{\alpha, \beta} \phi_{\beta, \gamma} = \phi_{\alpha, \gamma}.$$

The *strong semilattice of semigroups*  $S = \mathcal{S}[Y; S_\alpha; \phi_{\alpha, \beta}]$  consists of the disjoint union  $\bigcup_{\alpha \in Y} S_\alpha$  with the following multiplication: if  $x \in S_\alpha$  and  $y \in S_\beta$ , then

$$xy = (x\phi_{\alpha, \alpha \wedge \beta})(y\phi_{\beta, \alpha \wedge \beta}),$$

where  $\alpha \wedge \beta$  denotes the greatest lower bound of  $\alpha$  and  $\beta$ .

The following result proves that a certain type of strong semilattice of automaton semigroups is itself an automaton semigroup. Although it is of restricted scope, this result is of independent interest, and it will also be applied in the following section on small extensions of automaton semigroups.

**Proposition 8.** *Let  $S_1, \dots, S_k$  be automaton semigroups and  $T$  a finite semigroup with a right zero. Let  $Y$  be the semilattice where all the  $S_i$  are mutually incomparable and all greater than  $T$ , which is the minimum element of  $Y$ . Then the strong semilattice  $S = \mathcal{S}[Y; S_1, \dots, S_k, T; \phi_1, \dots, \phi_k]$  with  $\phi_i : S_i \rightarrow T$  is an automaton semigroup.*

*Proof.* For  $1 \leq i \leq k$ , let  $\mathcal{A}_i = (Q_i, A_i, \delta_i)$  be an automaton for  $S_i$ . Let  $P$  be a copy of  $T$  and  $B$  a copy of  $T^1$  and for  $1 \leq i \leq k$  let  $A_i^0 = A_i \cup \{0\}$ , where  $0$  is a new symbol not in any  $A_i$  or  $B$ . Let  $\mathcal{B} = (Q, C, \delta)$ , where  $Q = Q_1 \cup \dots \cup Q_k \cup P$ ,  $C = A_1^0 \times \dots \times A_k^0 \times B$  and  $\delta$  is defined as follows: Let  $c = (a_1, \dots, a_k, b)$  be any element of  $C$ . For  $p \in P$  we define  $(p, c)\delta = (z, (0, \dots, 0, bp))$ . For  $a \in A_i$  and  $q \in Q_i$ , let  $\pi_a$  and  $\tau_q$  be as in  $\mathcal{A}_i$ . We extend  $\tau_q$  to  $\tau'_q : A_i^0 \rightarrow A_i^0$  by defining  $a\tau'_q$  to be  $a\tau_q$  if  $a \neq 0$  and  $0$  if  $a = 0$ . The output on reading  $c$  in state  $q$  is  $(a'_1, \dots, a'_k, b\phi_i(q))$ , where  $a'_i = a_i\tau'_q$  and  $a'_j = 0$  for all  $j \neq i$ ; and we move to state  $q\pi_{a_i}$  if  $a_i \neq 0$  and to state  $z$  otherwise.

For  $p \in P$  we have  $C^\omega \cdot p \subseteq C(0, \dots, 0, z)^\omega$ , so the action of  $P^+$  on  $C^\omega$  depends only on its action on  $C$ , which is essentially just the action by right multiplication on  $B = T^1$ , so  $\langle P \rangle \cong T$ .

Fix some  $i \in \{1, \dots, k\}$ , and let  $C_i$  be the subset of  $C$  consisting of all tuples without  $0$  in their  $i$ -th component. Then every string in  $C^*$  is a prefix of some  $\alpha c \beta$ , where  $\alpha \in C_i^*$ ,  $c \in C \setminus C_i$  and  $\beta \in C^\omega$ . Now for  $w \in Q_i^+$

$$\alpha c \beta \cdot w = (\alpha \cdot w)(c \cdot w|_\alpha)z^\omega.$$

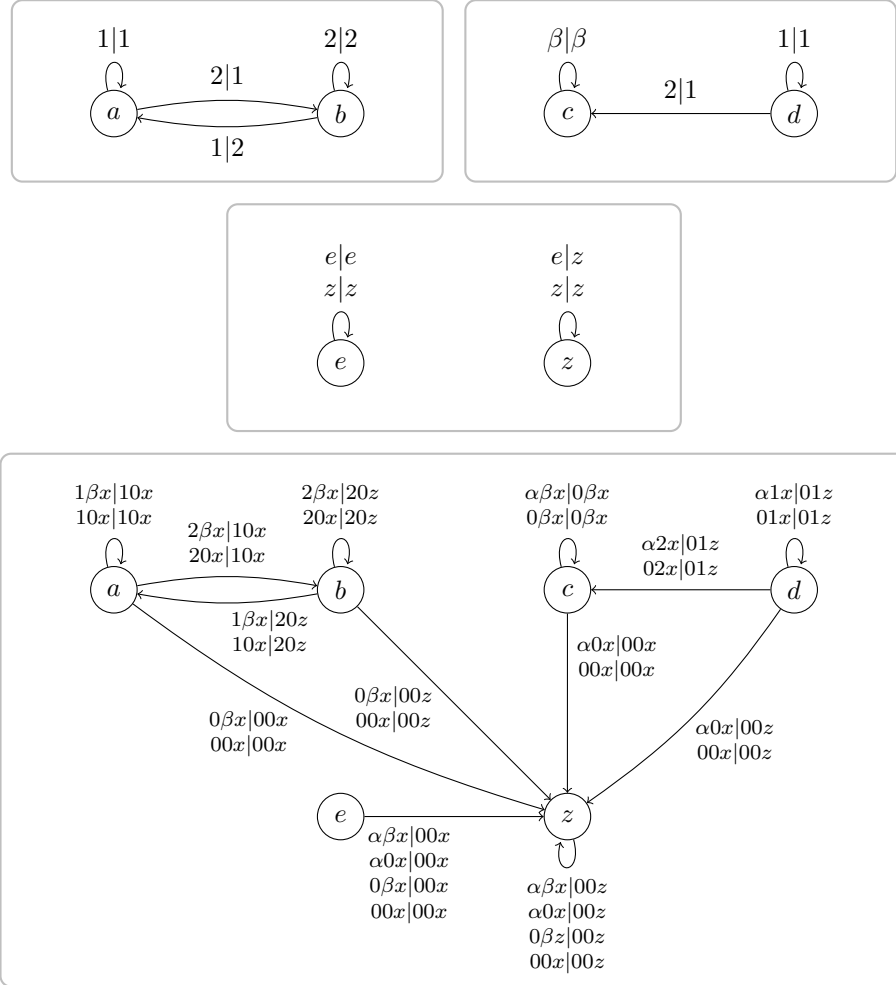

Figure 5: Below, the automaton for the strong semilattice of semigroups  $\mathcal{S}[Y; S_1, S_2, T; \phi_i]$ , where  $S_1 = F_2$  (with basis  $\{a, b\}$ ),  $S_2 = \mathbb{N}_0$  (with  $c$  being the additive identity of  $\mathbb{N}_0$  and  $d$  representing the natural number 1), and  $T = \{e, z\}$  (where  $e^2 = e$  and  $ez = ze = z^2 = z$ ), where  $a\phi_1 = e$  and  $b\phi_1 = z$ , and  $c\phi_2 = e$  and  $d\phi_2 = z$ . Throughout the diagram,  $\alpha$  and  $\beta$  are arbitrary symbols in  $\{1, 2\}$  and  $x$  is an arbitrary symbol in  $\{e, z\}$ . For reasons of space, triples  $(\kappa, \lambda, \mu)$  are abbreviated  $\kappa\lambda\mu$ . Above, the original automata for (clockwise from top left)  $F_2$ ,  $\mathbb{N}_0$ , and  $T$ .

Since the state transitions during the computation of  $\alpha \cdot w$  are governed entirely by the  $i$ -th components of the symbols in  $\alpha$ , which in turn are the same as in  $\mathcal{A}_i$ ,  $w|_\alpha$  depends only on  $\alpha$  and  $s_w$ , the element of  $S_i$  represented by  $w$ . If for a string  $\gamma \in C^*$  and  $j \in \{1, \dots, k+1\}$  we denote by  $\gamma(j)$  the string obtained by reading off the  $j$ -th components of symbols in  $\gamma$ , then we have  $(\alpha \cdot w)(i) = \alpha(i) \cdot w$  and  $(\alpha \cdot w)(j) = 0^m$  for  $j \notin \{i, k+1\}$ , where  $m = |\alpha|$ . Thus the action of  $Q_i^+$  on the first  $k$  components of strings in  $C^*$  is an action of  $S_i$ . Now we need to check the action on the final component. Let  $\alpha_j$  be the prefix of  $\alpha$  of length  $j$ , for  $0 \leq j \leq m$ , and let  $b_j$  be the final component of the  $j$ -th symbol in  $\alpha$ . Then  $(\alpha \cdot w)(k+1) = b'_1 \dots b'_m$  with  $b'_j = b_j \phi_i(w|_{\alpha_{j-1}})$ . Since each  $w_{\alpha_j}$  depends only on  $\alpha$  and  $w_s$ , this concludes the proof that the action of  $Q_i^+$  on  $C^*$  is an action of  $S_i$ . Moreover, this action is faithful, due to the action on the  $i$ -th component of strings being identical to the action in  $\mathcal{A}_i$ . So  $Q_i$  generates a subsemigroup of  $\Sigma(\mathcal{B})$  isomorphic to  $S_i$ .

Finally, we establish that the multiplication works correctly outside of the defining subsemigroups  $S_1, \dots, S_k, T$ . For any word  $w \in Q^+$  containing elements from more than one defining subsemigroup, we have  $C^\omega \cdot w \subseteq C(0, \dots, 0, z)^\omega$ . This is because acting by a state in  $P$ , or acting on a tuple with 0 in the  $i$ -th position by a state in  $Q_i$ , both cause a transition to the state  $z$ , which sends all strings to  $(0, \dots, 0, z)$ . Hence the action of ‘multi-subsemigroup’ words on  $C^\omega$  is determined entirely by their action on  $C$ . For  $c = (a_1, \dots, a_k, b) \in C$ ,  $p \in P$ ,  $q_i \in Q_i$  and  $q_j \in Q_j$  with  $i \neq j$ , we have

$$\begin{aligned} c \cdot pq_i &= (0, \dots, 0, bp) \cdot q_i = (0, \dots, 0, bp\phi_i(q)) = c \cdot \overline{pq_i}, \\ c \cdot q_i p &= (0, \dots, 0, a_i \tau_{q_i}, 0, \dots, 0, b\phi_i(q_i)) \cdot p = (0, \dots, 0, b\phi_i(q)p) = c \cdot \overline{q_i p}, \\ c \cdot q_i q_j &= (0, \dots, 0, a_i \tau_{q_i}, 0, \dots, 0, b\phi_i(q_i)) \cdot q_j = (0, \dots, 0, b\phi_i(q_i)\phi_j(q_j)) = c \cdot \overline{q_i q_j}, \end{aligned}$$

where  $\overline{w}$  denotes the element of  $S$  represented by  $w$ . Hence  $\Sigma(\mathcal{B}) \cong S$ .  $\square$

## 7 Small extensions

Recall that if  $S$  is a semigroup and  $T$  is a subsemigroup of  $S$  with  $S \setminus T$  finite, then  $S$  is a *small extension* of  $T$ .

In this section, we present some examples of small extensions of automaton semigroups that are again automaton semigroups. Our first example is the  $k = 1$  case of Proposition 8. (For  $k \geq 2$ , the semigroups in Proposition 8 are not small extensions of automaton semigroups.)

**Example 9.** *Let  $S$  be an automaton semigroup and let  $T$  be a finite semigroup with a right zero. Then if  $\phi : S \rightarrow T$  is any homomorphism, the strong semilattice  $\mathcal{S}(1 < 2; S, T; \phi)$  is an automaton semigroup.*

This example is interesting because it has the potential to lead to an answer

to one of the basic open questions about automaton semigroups (see [4, Open problem 5.3]):

**Question 10.** *Does there exist a non-automaton semigroup  $S$  such that  $S^0$  is an automaton semigroup?*

If we can prove that some similar strong semilattice with the finite semigroup  $T$  not having a right zero is not an automaton semigroup, then we will have an example of a semigroup that is not an automaton semigroup, but becomes one on adjoining a zero. We conjecture that following strong semilattices of semigroups are not automaton semigroups:

- $F_2 = \langle x, y \rangle$  above  $C_2 = \{e, f\}$  with  $\phi(x) = e, \phi(y) = f$ .
- $\mathbb{N}_0 = \langle 0, 1 \rangle$  above  $C_2 = \{e, f\}$  with  $\phi(0) = e, \phi(1) = f$ .

Example 9 can be generalised in a different direction:

**Proposition 11.** *Let  $S_1$  be an automaton semigroup and  $S_2$  a finite semigroup with a right zero. Then any semigroup  $S = S_1 \cup S_2$  having  $S_2$  as an ideal is an automaton semigroup.*

*Proof.* Let  $\mathcal{A}_1 = (Q_1, A, \delta_1)$  be any automaton for  $S_1$  and let  $\mathcal{A}_2 = (Q_2, B, \delta_2)$  be the automaton for  $S_2$  having  $Q_2 = S_2$ , with  $B$  be a copy of  $S_2^1$  (whose elements we will denote in the form  $\bar{b}$ ) and  $(t, \bar{b})\delta_2 = (z, \overline{bt})$  for  $t \in Q_2, \bar{b} \in B$ , where  $z$  is some right zero in  $Q_2$ . We construct an automaton  $\mathcal{A}$  with  $\Sigma(\mathcal{A}) = S$  as follows: For each  $s \in S_1$ , let  $\lambda_s$  and  $\rho_s$  be the transformations of  $B$  induced by the left and right actions respectively of  $s$  on  $S_2$ . Define  $\Lambda = \{\lambda_s \mid s \in S_1\} \cup \{\iota_B\}$ . Since  $\Lambda$  is a subsemigroup of the full (left) transformation semigroup of  $B$ , it is finite. Let  $C = (A \times \Lambda) \cup B$  and let  $\mathcal{A} = (Q_1 \cup Q_2, C, \delta)$  with  $\delta$  given by

$$\begin{aligned} (x, (a, \mu)) &\mapsto (x\pi_a, (a\tau_x, \mu\lambda_x)) & (x, \bar{b}) &\mapsto (z, \overline{b\rho_x}) \\ (y, (a, \mu)) &\mapsto (z, \overline{\mu y}) & (y, \bar{b}) &\mapsto (z, \overline{by}) \end{aligned}$$

for  $x \in Q_1, y \in Q_2, a \in A, \mu \in \Lambda, \bar{b} \in B$  and for  $\pi_a$  and  $\tau_x$  as in  $\mathcal{A}_1$ .

We begin by considering the action of words in  $Q_2^+$ . For  $(a, \mu) \in A \times \Lambda, \bar{b} \in B, \alpha \in C^\omega$  and  $y \in Q_2$ , we have  $(a, \mu)\alpha \cdot y = \overline{\mu y}z^\omega$  and  $\bar{b}\alpha \cdot y = \overline{by}z^\omega$ . Thus the action of  $w \in Q_2^+$  on  $C^\omega$  depends only on its actions on  $\Lambda$  and on  $B$ , both of which depend only on the element of  $S_2$  represented by  $w$ . Moreover, the action on  $\Lambda$  is faithful, since  $\iota_B \bar{b} = \bar{b}$  for all  $\bar{b} \in B$ . Hence the subsemigroup of  $\Sigma(\mathcal{A})$  generated by  $Q_2$  is isomorphic to  $S_2$ .

Next we consider the action of words in  $Q_1^+$ . For  $\alpha \in (A \times \Lambda)^*, \bar{b} \in B, \gamma \in C^\omega$  and  $w \in Q_1^+$  we have

$$\alpha \bar{b} \gamma \cdot w = (\alpha \cdot w) \overline{b\rho_w|_\alpha} z^\omega.$$

Let  $s_w$  be the element of  $S_1$  represented by  $w$  in  $\Sigma(\mathcal{A}_1)$ . If  $\alpha = (a_1, \mu_1) \dots (a_k, \mu_k)$ , let  $\alpha \cdot w = (c_1, \nu_1) \dots (c_k, \nu_k)$ . Then in  $\mathcal{A}_1$  we have  $a_1 \dots a_k \cdot w = c_1 \dots c_k$ . Since  $\Sigma(\mathcal{A}_1) = S_1$ , this means that  $\mathcal{A}$  restricted to states in  $Q_1$  defines a faithful action of  $S_1$  on the first component of strings in  $(A \times \Lambda)^*$ . Also note that  $\rho_w|_\alpha$  depends only on  $\alpha$  and  $s_w$ , so that the only possible obstacle to  $\langle Q_1 \rangle$  being isomorphic to  $S_1$  would be the action of  $w$  on the second component of strings in  $(A \times \Lambda)^*$  not depending only on  $s_w$ . However, if for  $0 \leq i \leq k-1$  we let  $\alpha_i$  be the prefix of  $\alpha$  of length  $i$ , then  $\nu_{i+1} = \mu_{i+1} \lambda_w|_{\alpha_i}$ , and so the second component of  $\alpha \cdot w$  also depends only on  $s_w$  and  $\alpha$ . Hence  $Q_1$  generates a subsemigroup of  $\Sigma(\mathcal{A})$  isomorphic to  $S_1$ .

It remains to establish that products  $s_1 s_2$  and  $s_2 s_1$  with  $s_i \in S_i$  act correctly. Since  $C^\omega \cdot S_2 \subseteq Cz^\omega$ , we only need to consider the action on  $C$ . For  $a \in A$ ,  $\mu \in \Lambda$ ,  $\bar{b} \in B$  and  $s_i \in S_i$  with  $s_1 s_2 =_S s$  and  $s_2 s_1 =_S s'$  we have

$$\begin{aligned} (a, \mu) \cdot s_1 s_2 &= (a\tau_{s_1}, \mu\lambda_{s_1}) \cdot s_2 = \overline{\mu\lambda_{s_1} s_2} = (a, \mu) \cdot s, \\ (a, \mu) \cdot s_2 s_1 &= \overline{\mu s_2} \cdot s_1 = \overline{\mu s_2 \rho_{s_1}} = (a, \mu) \cdot s', \\ \bar{b} \cdot s_1 s_2 &= \overline{\bar{b} \rho_{s_1}} \cdot s_2 = \overline{\bar{b} \rho_{s_1} s_2} = \bar{b} \cdot s, \\ \bar{b} \cdot s_2 s_1 &= \overline{\bar{b} s_2} \cdot s_1 = \overline{\bar{b} s_2 \rho_{s_1}} = \bar{b} \cdot s'. \end{aligned}$$

Hence  $\Sigma(\mathcal{A}) \cong S$  and so  $S$  is an automaton semigroup.  $\square$

In [17], Maltcev and Ruškuc gave a construction for a type of small extension as follows. Let  $S$  be any semigroup acting on a finite set  $X$  (on the right). Let  $x^s$  denote the result of acting on  $x \in X$  by  $s \in S$ . The semigroup  $S[X]$  is defined to be the union of  $S$  and  $X$ , with multiplication given by

$$st = st, \quad xs = x^s, \quad sx = x, \quad xy = y,$$

for  $s, t \in S$ ,  $x, y \in X$ .

**Example 12.** *Let  $S$  be an automaton semigroup and  $X$  a finite set. Then the semigroup  $S[X]$  is an automaton semigroup.*

*Proof.* This follows immediately from Proposition 11, since  $X$  is both an ideal of  $S[X]$  and a right zero semigroup. Note that the automaton from Proposition 11 may be simplified in this case, since every element of  $S$  acts as a left identity on  $X$  and hence the set  $\Lambda$  is superfluous. An example is shown in Figure 6.  $\square$

It is not obvious how to construct a (right) automaton for the dual of  $S[X]$  (where  $S$  acts on the left and  $X$  is a left zero semigroup), because the idea of Proposition 11 relies heavily on using a right zero to ‘forget’ information once it is no longer required. A left zero cannot be used in the same way. This leads to the following question.

**Question 13.** *Does there exist a semigroup  $S$  such that  $S$  is a right automaton semigroup but not a left automaton semigroup?*

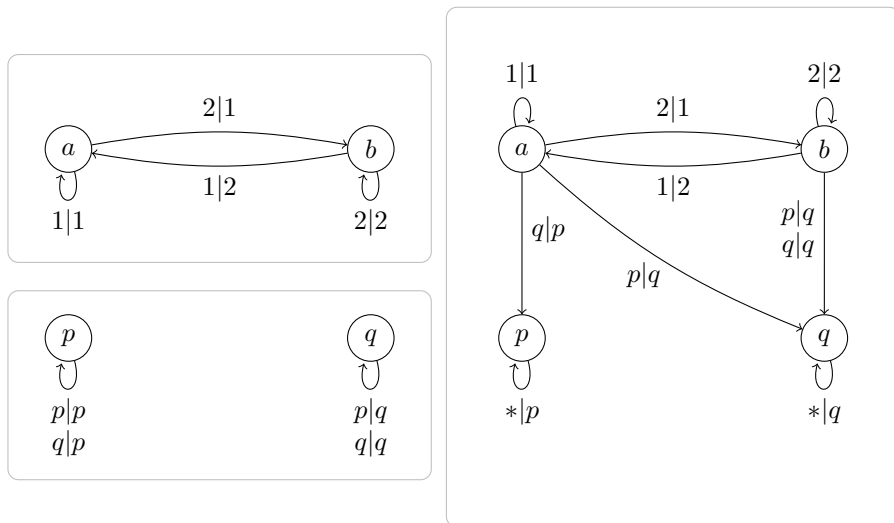

Figure 6: On the right, the automaton for the semigroup  $F_2[X]$  with  $F_2 = \langle a, b \rangle$ ,  $X = \{p, q\}$  and  $p^a = q$ ,  $q^a = p$ ,  $p^b = q$ ,  $q^b = q$ . On the left, the original automata for  $F_2$  and  $X$ .

## 8 Some new examples of non-automaton semigroups

There is so far no general method known for proving a finitely generated semigroup not to be an automaton semigroup, other than by showing that it fails to have one of the properties satisfied by all automaton semigroups, such as being residually finite or having solvable generalised word problem. Previously, the only known example of a residually finite non-automaton semigroup was  $\mathbb{N}$ , the free semigroup of rank 1 [4, Proposition 4.3].

Every subsemigroup of  $\mathbb{N}$  is finitely generated [20, Theorem 2.7]. (This also follows from noting that any subsemigroup  $S$  of  $\mathbb{N}$  is isomorphic to one whose elements have least common multiple 1, and that such a semigroup contains all but finitely many natural numbers by Euclid's algorithm and is thus a large subsemigroup of the finitely generated semigroup  $\mathbb{N}$ . Finite generation is preserved on passing to large subsemigroups [21, Theorem 1.1].) Furthermore, subsemigroups of  $\mathbb{N}$  are residually finite. In this section we show that they do not arise as automaton semigroups. The importance of this result is that we now have a countable set of finitely generated residually finite non-automaton semigroups.

In fact we will show slightly more. We establish that no subsemigroup of  $\mathbb{N}^0$  (the free semigroup of rank 1 with a zero adjoined, not to be confused with  $\mathbb{N}_0$ , the free monoid of rank 1) is an automaton semigroup. This establishes

that subsemigroups of  $\mathbb{N}$  are not potential examples for a ‘yes’ answer to Question 10 on the existence of non-automaton semigroups which become automaton semigroups upon adjoining a zero.

Our approach is akin to the proof of [4, Proposition 4.3], in that we use wreath recursions to show that any hypothetical automaton for a subsemigroup of  $\mathbb{N}$  must contain a state corresponding to a periodic element. We make use of the following simple lemma.

**Lemma 14.** *Let  $\mathcal{A} = (Q, B, \delta)$  be an automaton such that  $\Sigma(\mathcal{A})$  has a zero. If there exist  $q, z \in Q$ , with  $z$  representing the zero element of  $S$ , such that  $q$  recurses only to itself and  $z$ , then  $q$  represents a periodic element of  $S$ .*

*Proof.* Let  $q = (q_1, \dots, q_k)\tau$  be the wreath recursion for  $q$ , with  $q_i \in \{q, z\}$ . Then for any  $n$ , we have  $q^n = (u_{n1}, \dots, u_{nm})\tau^n$ , where each  $u_{ni}$  can be expressed as a product of  $n$  elements from  $\{q, z\}$ , and is hence in  $\{q^n, z\}$ . But this means that two distinct powers of  $q$  must have identical recursion patterns (that is, there exist distinct  $m, n$  such that  $\tau^m = \tau^n$ , with  $u_{mi} = q^m$  if and only if  $u_{ni} = q^n$ ) and hence represent the same element of  $S$ , and so  $q$  is periodic.  $\square$

**Theorem 15.** *No subsemigroup of  $\mathbb{N}^0$  is an automaton semigroup.*

*Proof.* Let  $S$  be a subsemigroup of  $\mathbb{N}^0$  and let  $X = \{(z), m_1, \dots, m_n\}$  be a minimal generating set for  $S$ , with  $m_1 < m_2 < \dots < m_n$ , where  $z$  represents the zero of  $\mathbb{N}^0$  and the brackets indicate that  $z$  may not be present in  $X$ . Suppose that  $S = \Sigma(\mathcal{A})$  for some automaton  $\mathcal{A}$ , and let  $Q$  be the state set of  $\mathcal{A}$ . We denote a state in  $Q$  representing an element  $i$  of  $\mathbb{N} \cup \{z\}$  by  $q_i$ . In particular, we have  $q_i \in Q$  for every  $i \in X$ . Let  $k \in \mathbb{N}$  be maximal such that  $q_k \in Q$  and write  $k = \alpha_1 m_1 + \dots + \alpha_n m_n$  with  $\alpha_i < m_{i-1}$  for  $2 \leq i \leq n$ . Consider the wreath recursion for  $q_k$  obtained from  $q_k = q_{m_1}^{\alpha_1} \dots q_{m_n}^{\alpha_n}$ . We have  $q_k = (u_1, \dots, u_d)\rho$ , where each  $u_i$  is a state in  $Q$  which can be expressed as a word the form  $p_1^{\alpha_1} \dots p_n^{\alpha_n}$  for  $p_i \in Q$ . The smallest non-zero element of  $S$  that can be expressed in this form is  $l := m_1 \alpha$ , where  $\alpha = \min\{\alpha_i\}$ . Thus each  $u_i$  is in  $\{z, q_l, q_{l+1}, \dots, q_k\}$ . If  $k = l$ , then this means that  $q_k$  recurses only to  $z$  and itself and is thus periodic by Lemma 14. So assume  $l < k$ . Let  $q_l = (v_1, \dots, v_d)\sigma$ , and note that  $v_i \in \{z, q_l, \dots, q_k\}$  for all  $i$ . Now consider two wreath recursions for the element  $kl = lk$  of  $\mathbb{N}$ :

$$\begin{aligned} q_{kl} &= q_k^l = (w_1, \dots, w_d)\rho^l \\ &= q_l^k = (x_1, \dots, x_d)\sigma^k \end{aligned}$$

where each  $w_i$  is in  $Q^l$ , while each  $x_i$  is in  $Q^k$ , and  $w_i =_S x_i$  for all  $i$ . If all  $w_i$  are  $z$ , then  $q_{kl}$  is periodic, so assume that some  $w_i \neq z$ . Clearly one way to achieve  $w_i =_S x_i$  is if  $w_i = q_k^l$  and  $x_i = q_l^k$ . And indeed this is the only possible solution, since replacing any state in  $w_i$  would result in a word representing a smaller element of  $S$ , while replacing any state in  $x_i$  would result in a word



representing a larger element of  $S$  (since the states are all in  $\{q_l, \dots, q_k\}$ ). Hence  $q_k$  and  $q_l$  both recurse only to themselves and  $z$  and are thus periodic, again by Lemma 14. But this is a contradiction, since  $S$  has no periodic elements, and hence the automaton  $\mathcal{A}$  cannot exist.  $\square$

**Question 16.** *Is there some general technique – perhaps a kind of ‘pumping lemma’ – that gives a general tool for proving a finitely generated residually finite semigroup is not an automaton semigroup?*

## Acknowledgements

The second author was supported by an Investigador FCT fellowship (IF/01622/2013/CP1161/CT0001). Much of the research leading to this paper was undertaken during a visit by the first author to the Centro de Matemática e Aplicações, Universidade Nova de Lisboa. We thank the centre and university for their hospitality. This visit was partially supported by the FCT exploratory project IF/01622/2013/CP1161/CT0001 (attached to the second author’s fellowship).

## References

- [1] L. Bartholdi, R. Grigorchuk, and V. Nekrashevych. From fractal groups to fractal sets. In *Fractals in Graz 2001*, Trends Math., pages 25–118. Birkhäuser, Basel, 2003.
- [2] L. Bartholdi, R. I. Grigorchuk, and Z. Šunić. Branch groups. In *Handbook of Algebra, Vol. 3*, pages 989–1112. North-Holland, Amsterdam, 2003.
- [3] T. Brough and A. J. Cain. Automaton semigroup constructions. *Semigroup Forum*, 90(3):763–774, 2015. URL: <http://dx.doi.org/10.1007/s00233-014-9632-x>, doi:10.1007/s00233-014-9632-x.
- [4] A. J. Cain. Automaton semigroups. *Theoret. Comput. Sci.*, 410(47–49):5022–5038, 2009. doi:10.1016/j.tcs.2009.07.054.
- [5] A. J. Cain and V. Maltcev. For a few elements more: A survey of finite Rees index. arXiv:1307.8259.
- [6] P. Gillibert. The finiteness problem for automaton semigroups is undecidable. *Internat. J. Algebra Comput.*, 24(1):1–9, 2014. URL: <http://dx.doi.org/10.1142/S0218196714500015>, doi:10.1142/S0218196714500015.

- [7] R. Grigorchuk and Z. Šunić. Self-similarity and branching in group theory. In *Groups St. Andrews 2005. Vol. 1*, volume 339 of *London Math. Soc. Lecture Note Ser.*, pages 36–95. Cambridge Univ. Press, Cambridge, 2007.
- [8] R. I. Grigorchuk. Degrees of growth of finitely generated groups and the theory of invariant means. *Izv. Akad. Nauk SSSR Ser. Mat.*, 48(5):939–985, 1984.
- [9] R. I. Grigorchuk, V. V. Nekrashevich, and V. I. Sushchanskiĭ. Automata, dynamical systems, and groups. *Proc. Steklov Inst. Math.*, 231(4):128–203, 2000.
- [10] R. I. Grigorčuk. On Burnside’s problem on periodic groups. *Funktsional. Anal. i Prilozhen.*, 14(1):53–54, 1980.
- [11] C. K. Gupta, N. D. Gupta, and A. S. Oliynyk. Free products of finite groups acting on regular rooted trees. *Algebra Discrete Math.*, (2):91–103, 2007.
- [12] J. M. Howie. *Fundamentals of Semigroup Theory*, volume 12 of *London Mathematical Society Monographs (New Series)*. Clarendon Press, Oxford University Press, New York, 1995.
- [13] I. Klimann. The finiteness of a group generated by a 2-letter invertible-reversible Mealy automaton is decidable. In *30th International Symposium on Theoretical Aspects of Computer Science*, volume 20 of *LIPICs. Leibniz Int. Proc. Inform.*, pages 502–513. Schloss Dagstuhl. Leibniz-Zent. Inform., Wadern, 2013.
- [14] I. Klimann, J. Mairesse, and M. Picantin. Implementing computations in automaton (semi)groups. In N. Moreira and R. Reis, editors, *Implementation and Application of Automata*, volume 7381 of *Lecture Notes in Computer Science*, pages 240–252. Springer, Berlin, 2012. URL: [http://dx.doi.org/10.1007/978-3-642-31606-7\\_21](http://dx.doi.org/10.1007/978-3-642-31606-7_21), doi:10.1007/978-3-642-31606-7\_21.
- [15] M. Lothaire. *Algebraic combinatorics on words*, vol. 90 of *Encyclopedia of Mathematics and its Applications*. Cambridge University Press, Cambridge, 2002.
- [16] V. Maltcev. Cayley automaton semigroups. *Internat. J. Algebra Comput.*, 19(1):79–95, 2009. doi:10.1142/S021819670900497X.
- [17] V. Maltcev and N. Ruškuc. On hopfian cofinite subsemigroups. 2012. Submitted. arXiv:1307.6929.
- [18] V. Nekrashevych. *Self-similar groups*, volume 117 of *Mathematical Surveys and Monographs*. American Mathematical Society, Providence, RI, 2005.
- [19] M. Picantin. Private communication.

- [20] J. C. Rosales and P. A. García-Sánchez. *Numerical semigroups*, volume 20 of *Developments in Mathematics*. Springer, New York, 2009. URL: <http://dx.doi.org/10.1007/978-1-4419-0160-6>, doi:10.1007/978-1-4419-0160-6.
- [21] N. Ruškuc. On large subsemigroups and finiteness conditions of semigroups. *Proc. London Math. Soc. (3)*, 76(2):383–405, 1998. doi:10.1112/S0024611598000124.
- [22] B. Steinberg, M. Vorobets, and Y. Vorobets. Automata over a binary alphabet generating free groups of even rank. *Internat. J. Algebra Comput.*, 21(1-2):329–354, 2011. URL: <http://dx.doi.org/10.1142/S0218196711006194>, doi:10.1142/S0218196711006194.