

Deterrence Dispensed presents

FMDA DD17.2

Revised for
pinned-in rear rails

FMDA
version 1.4

Preface

The DD17.2 Glock 17 frame is an update to FMDA's original 'DIY' spec Glock frame. After having over a year of testing, adoption, and feedback on the first-generation frames, three things became apparent: the screw-in rear rails were a weak point of the design. The frame needed quite a few dimensional tweaks to make assembly a little easier. And a crop of quality rail vendors (like Avesrails.com and Riptiderails.com) had popped up to offer people commercial sales of rails, such that an individual didn't need to do their own rails from scratch. This project/update was aimed at solving the first two aforementioned items by leveraging the third item, as well as by some refinements to the design. This frame is compatible with G22 uppers!

****Note:** The 'G5Spring' frame version uses a Glock Gen5 style spring setup for the slide latch. This amounts to a little easier/cheaper build but is optional. Read the Shopping List section for more info.**

You can watch this assembly process on video here:
https://lbry.tv/@Ivan's_CAD_Streams:c/FMDADD17.2GlockFrameTutorial:e

Make sure you refer to the README for basic info/print settings for this frame!

I recommend you use this document to supplement the video, having text-based steps helps keep things organized, being able to see things in real time helps clear up confusing instructions.

Do not be intimidated by the length of the build video/tutorial – this process is very easy (perhaps even easier than finishing an 80% Glock frame). If you run into issues, the troubleshooting section at the end of this document should help you out.

If you have found this tutorial useful, consider sending me Bitcoin to further development of this sort of thing – there is much more to explore in 3D printed guns, DIY guns, DIY ammo, etc.



BTC: bc1qm9q5lu5skq8e50yqz8hps69r44lmue6sfq5y2y

Glock
Documentation
Glockumentation

Remember that it is our shared responsibility to be safe and smart with firearms and show the world there is a peaceful way to own guns – take the time to get training, to learn basic (and advanced) safety rules, and to share the hobby with everyone interested – those most scared of guns in the hands of the people are often the ones who have no experience with guns in the first place.

Table of Contents

Preface	2
Shopping List	5
Build Tutorial	8
Step 1: Lay Out Your Parts/Prep Work	8
Step 2: Install Magazine Catch	12
Step 3: Install Front Rail Block	16
Step 4: Install Slide Latch System	18
A. NON-G5Spring Frame	18
B. G5Spring Frame	20
Step 4: Install Rear Rails, Trigger Mechanism, And Locking Block	23
Step 5: Install Slide, Function Test	37
FAQ/Troubleshooting	39

Shopping List

This list will cover what supplies you will need for a DD17.2 build. You will need some basic tools, such as a 3mm and 4mm drill bit, some screwdrivers/punches, a mallet, a drill, and optionally a pair of needle-nosed pliers. The build video details the tools I use at the beginning – I recommend you take a peek just to make sure you're on the right path in that regard.

Glock Parts Kit

The big-ticket item for this build will be a Glock parts kit. These kits used to be much more common than they are at the time of publication (December 2020). As of publication, the best sources for kits are aftermarket shops like Rockslide, used auctions (like Gunbusters on Gunbroker), the occasional police "trade-in" parts kits sales, and sometimes when outfits like BigTexOutdoors has OEM uppers for sale. Ebay can be a good source as well. While full kits can be hard to find sometimes, it is possible to put together a kit from various parts/companies. JSDSupply sometimes has good deals on aftermarket kits, but their QC can be a little bit sketchy.

****Note:** this frame is compatible with Glock 22 (40SW) uppers. Refer to the end of the "FAQ/Troubleshooting" section to make sure you are set up to run a 40SW upper)**

You will need: A Glock slide, barrel, and uppers parts kit (recoil spring assembly, firing pin safety and spring, striker assembly, channel liner (if your slide doesn't have one), extractor and extractor spring assembly, rear plate, and sights (if your slide doesn't have them)). You will also need a complete Glock lower parts kit – this will be a trigger housing, trigger bar/trigger, slide stop, slide latch spring, slide latch, magazine catch, magazine catch spring, as well as a **LOCKING BLOCK**. I emphasize locking block because some kits that claim to be complete don't include them. For the DD17.2, you will need a Glock 17 Gen 3 "Three Pin" locking block (Glock part number 1447).



Glock parts kit (circled)

Glock Rail Kit

There are several vendors who offer rails – the most popular are Avesrails.com and Riptiderails.com. Both are planning on carrying the necessary rails for this build. Spookyrails.com may offer them in the future, as might other outfits. The old version front rails (FMDA G17) will work in this frame.

I (Ivan) have tested/verified these rails for this frame:

https://www.avesrails.com/FMDA-DDxx2-Rear-Rail_p_27.html <- Just the rear rail

https://www.avesrails.com/FMDA-DD172-Rail-Kit-_p_28.html <- Complete rail kit

The rails should be marked/listed as being “FMDA DDxx.2 compatible” (where xx is the Glock model you are building), and should look like the picture below. You will need a 3mmx28mm pin/screw to hold the front rail in the frame – some vendors will furnish this pin, others will leave you to buy one from Amazon or wherever. Roll pins work best, but I’ve had success just using a cut down M3 bolt.

At the time of publication, I can confirm that the rails from Avesrails.com fit and function perfectly. I am in touch with Riptiderails and Spookyrails, and am sure that once they have offerings up they will have been quality controlled/checked by myself or another trusted dev. Other outfits may or may not follow any testing/prooing requirement – if they don’t have video of the rails in use and/or don’t have any real verification, (claimed or proven) you may want to be wary. Trust reviews where possible.



Aves rail kit (circled)

Do note that “printyour2a” rear rails will NOT work in these frames – they are too wide in the body and don’t have the angled brace (required to prevent doublefires and other mishaps) integrated into the rail body (some of their frame designs integrate this brace into the frame, thus another reason why these rails will not be compatible).

(Optional) 3mmx10mm Compression Spring

If you print the 'G5Spring' variant of the frame, then you will need to buy a 3mmx10mm compression spring. You should also be able to use a 1/8" x 3/8" compression spring. This option ends up making a little stronger/cheaper/easier to assemble frame, but is optional – being able to grab a spring off of amazon or at your local store beats out having to hunt down a spring from ebay or glockstore.

Inch sized springs: <https://www.mcmaster.com/1986K44/>

Metric sized springs: <https://www.amazon.com/uxcell-Compression-Stainless-Compressed-Capacity/dp/B08FDWZGVC>

Tooling:

You will need a 3mm and 4mm drill bit. You will need a drill, a couple screwdrivers (for removing support material), a punch (size isn't really important), and a hammer. A pair of needle-nosed pliers can help, but are not required.

Build Tutorial

I recommend you read this section in its entirety, then watch the build video while you go about building your Glock. It's a fairly easy process but following the video should save you from wasting any time due to silly mistakes.

****REFER TO THE README FOR BASIC PRINT INFORMATION****

Step 1: Lay Out Your Parts/Prep Work

This step is simple – gather up all your parts and lay them out. Make sure you have all the parts you need (this is covered in the previous section of this document). Remove **ALL** supports from your printed frame – as a little tip, you can view everywhere supports will be printed on your frame by viewing the layer-by-layer view in your slicing software. Every place that your slicer indicates is support material should be removed prior to starting.

One thing to make sure of before starting is that your frame isn't badly warped – the top of the frame (the area the slide will sit above) should be very close to perfectly flat. If it is bowed up or down, you may have trouble assembling your frame – I recommend you restart your print with more attention paid to print settings (specifically cooling settings, you need less cooling fan if you are having warping).



Spread of parts and tools used in assembling a DD17.2 Glock Frame

It is very important that you remove ALL of the support material from the rear (trigger block) pocket, the middle (locking block) pocket, and the front (rail block) pocket. Even a small amount of support interface material will prevent you from installing your parts, so you must scrape all of it out. I recommend using a small screwdriver and just prying/scraping with it to get all the support material out of the frame. Don't worry too much about scratching the frame in these areas – when the parts are installed, you won't be able to see the scratches.

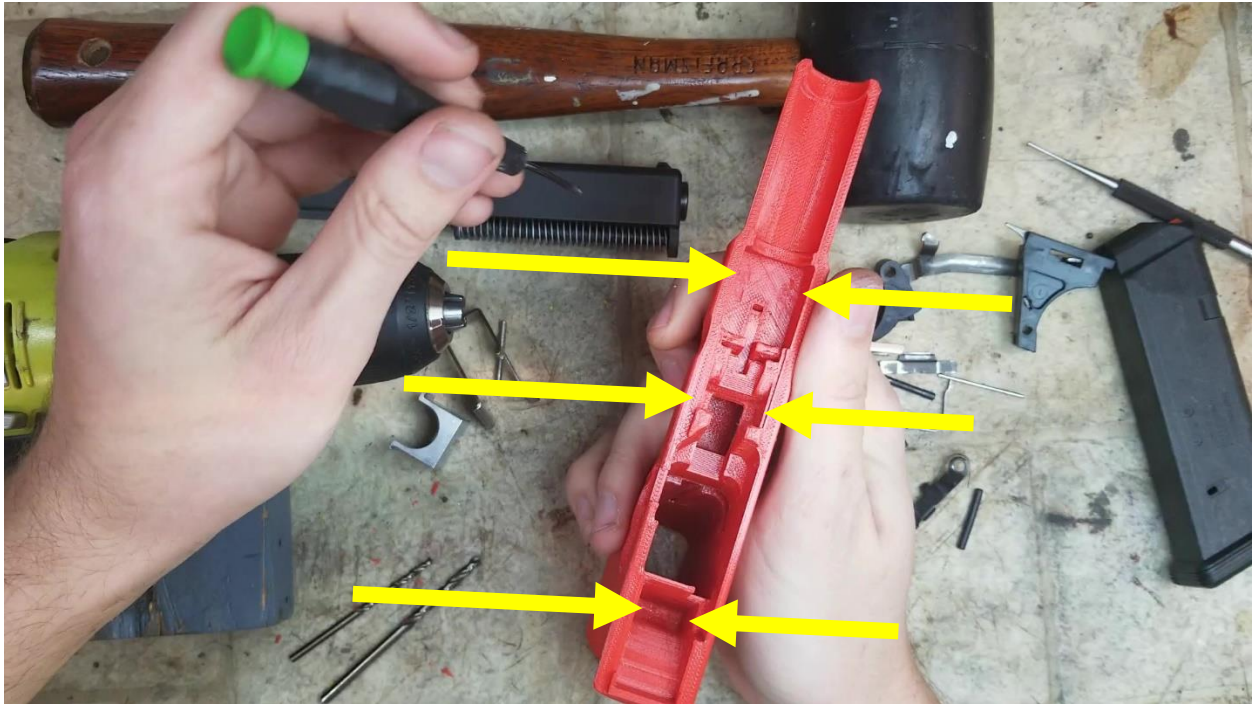

View of all three pockets needing close attention, as well as a suitable screwdriver to remove stubborn supports. The six arrows indicate the areas where stubborn support material may remain. Get it all out.

Next, you can/should clearance all of the pin holes in the frame. While you can wait to do this until the step when a pin needs to be inserted in the hole, I recommend you do it now. Take your drill and 4mm drill bit and drill this hole:



You should drill the hole while holding the drill as straight as possible. Keep the drill moving while pushing the drill bit in and out of both holes. You will want to drill these holes until the largest pin in your parts kit can pass through both holes.

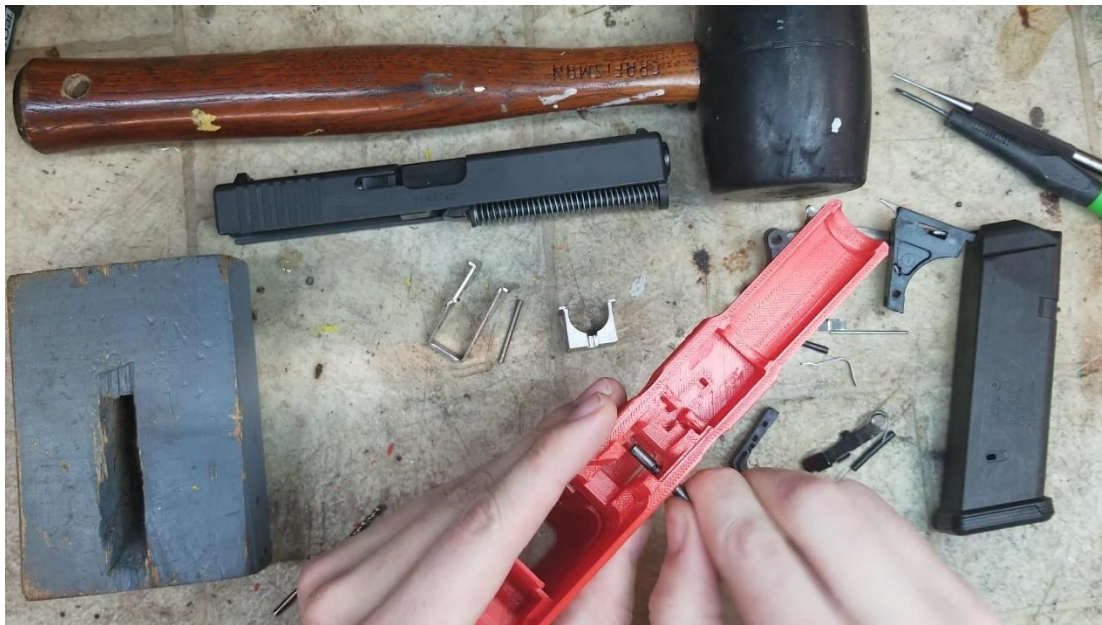

Use the large pin to ensure the hole is wide enough for the pin to pass through.

Next, take your 3mm drill bit and drill out these three holes:

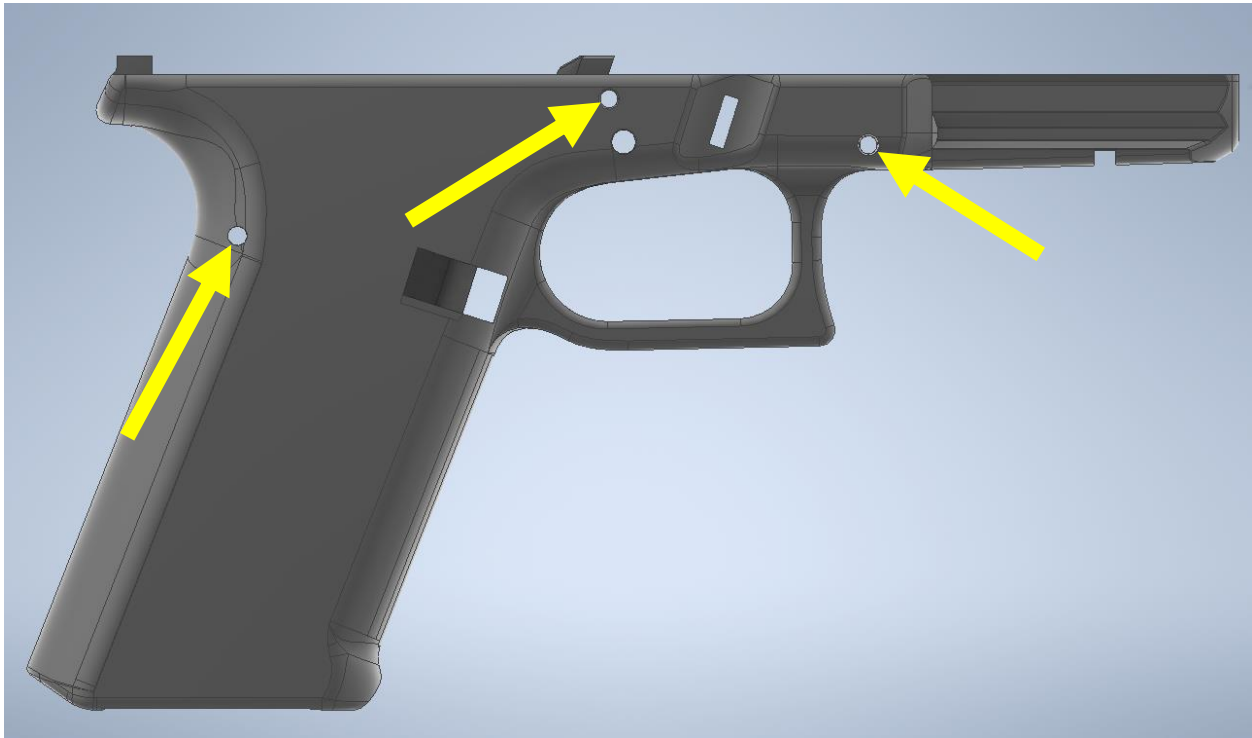

These holes should be drilled out as straight as you can manage. They shouldn't need to be drilled back and forth as much as the 4mm pin hole required. In order to check them, you can take the small polymer pin (it looks like a plain, round pin) and ensure it can pass through the rearmost pin hole. Take the pin that looks like a dumbbell (it's larger on either end and a little more skinny in the middle) and ensure it can fit through the hole in the middle of the frame. Finally, if you have a 3mm roll pin, you shouldn't need to check the front hole. If you are using a normal pin or a screw, you can insert it into the front hole and ensure it can pass through.

Step 2: Install Magazine Catch

Take your magazine catch spring and magazine catch, as well as your frame. These two parts should be very easy to install, provided you removed all support material already and followed the print settings recommended in the readme.

Starting with just the magazine catch, insert it into the frame. It should insert easily (with only a little drag against the frame) and move freely. If it drags a lot or is hard to move, remove it from the frame and ensure ALL support material is removed from the magazine catch slot in the frame.



Test fitting the magazine catch

If for some reason your magazine catch doesn't move freely even after ensuring all supports are removed (and you are sure you followed the print settings in the readme), you can use a rat-tailed file and a screwdriver to remove a little material from the slot until the magazine catch moves freely (this shouldn't be required and is a sign that your settings are wrong/printer isn't dialed in).

After ensuring proper fitment of the magazine catch, remove it from the frame. Take your magazine catch spring and (optionally) a pair of needle-nosed pliers. Place the magazine catch spring down into the frame – it should be a tiny bit snug in the hole, but should insert with just a little pressure. If you feel some resistance, try to get it lined up and push down on the top of the spring using a screwdriver.



Installing the mag catch spring. The hole is located where the arrow points.

Once fully seated, your spring should be sticking up into the magazine catch slot in the frame by a few millimeters (the top of the spring should be about 1/3 of the way to the top of the magazine slot itself, if you view from the side of the frame). Watching the video (linked at the beginning of this document) may help you out if you have issues with this step.



Mag catch spring fully inserted

Take your mag catch and insert it until it runs into the spring. Take a small screwdriver from the other side of the mag catch slot and push the spring backwards (towards the inside of the magwell) so that you can push the mag catch past the spring.



Moving spring past the mag catch while pushing the mag catch into the frame

Finally, push the mag catch as far into the frame as it will go. Take a screwdriver and push the tip of the mag catch spring to the right (the side that you stuck the magazine catch in from) until the spring pops into the mag catch.



Pushing the spring to the right

If you are pushing your spring as far as you can to the right and it isn't snapping to the mag catch, one of two things may be happening. If your spring or mag catch isn't OEM, there may be an issue in length of the spring/height of the cutout on the mag catch. Look closely at where the spring meets the mag catch when you push the spring over – if the spring looks like it is too tall, you either don't have it seated far enough (push down on it) or it might be too long. Some aftermarket springs are cut slightly longer. You can shorten it just a hair with a file or Dremel tool to get it to fit. This shouldn't be necessary on OEM springs/magazine catches.



Spring snapped into the proper position after pushing it to the right

Finish up by testing the mag catch. Insert a magazine and check for three things – that one the magazine is fully inserted the magazine catch snaps back into place on its own, that after the magazine catch snaps back you cannot yank the magazine out by pulling on the bottom, and that when you press the magazine catch (to release the magazine) the magazine falls out of the frame on its own.

If the first event doesn't happen your magazine catch spring might not be fully inserted (push it in further), it might be a tiny amount too long (file it down just a little), or you didn't ensure that your magazine catch could move freely before installing parts. In order to remove the magazine catch spring, simply push the magazine catch into the frame as far as it can go (like you did when you installed the spring) then use a screwdriver to push the spring to the right while lifting it backwards (towards the inside of the magwell). Remove these springs can take a little practice, don't get frustrated.

If the second even doesn't happen (you can yank the magazine out) your magazines may be junky (stick to OEM Glock, ETS, PMAG, and printed (Menendez Mag) magazines), you may be using a junky mag catch (stick with OEM or good quality brands) or you may actually have the issue described above and didn't notice it – ensure that the first event isn't happening and follow those troubleshooting steps.

If the third even happens, you may have some support material/print defects in the magazine well – ensure these are all removed.

Step 3: Install Front Rail Block

Take your frame and front rail block, as well as the front rail block pin/screw. You should be able to drop the front rail block right into the frame – if it's a little tight, take a screwdriver and scrape the corners of the rail block pocket to ensure they are square (watch the video for how exactly to do this, if needed). If you got all the supports out of the bottom of the pocket, the pin hole for the rail and frame should line up – install your pin/screw. If you are using a roll pin, realize that roll pins have to compress to fit into the hole – it might take a little elbow grease and a proper roll pin punch to get a roll pin installed.



Front rail block placed in frame



Front rail pin installed. You may need to use a hammer and punch.

Next, check two things: the top of your rail block should be parallel to the frame itself. If it isn't, this could be due to warp in the frame (check if the frame itself is straight, refer to the start of this section if it isn't). If the frame looks straight, then you should ensure that there is no support material remaining underneath the rail block. Once you've ensure the rail block is as parallel as it can be, take your slide (it can be the whole slide assembly or just the slide) and guide it onto the rails. Ensure that the slide isn't rubbing hard on the rails or the frame itself. If it rubs hard on either (so much that you can't get the slide to push very far onto the rail) you don't have the rail block installed straight enough (something underneath it) or the frame is badly warped. If you have issues with the slide assembly fitting check if the slide without the barrel or recoil spring installed still has the issue.



The slide should at least fit on this far without binding or dragging on the frame.

Step 4: Install Slide Latch System

You have two options when installing the slide latch system – you can use the original Glock Gen 3 slide latch spring for your frame, or if you printed the 'G5Spring' variant of the frame, you can use an 3mmx10mm spring instead of the OEM Glock flat spring. Be aware of which frame you printed, and follow the directions for installing the correct slide latch system.

A. NON-G5Spring Frame

Take your frame, slide latch spring, and slide latch. These parts will install exactly like a factory Glock. Place the shorter, straight end of the spring down into the little cutout in the rail – there's a hole in the frame to accept it.

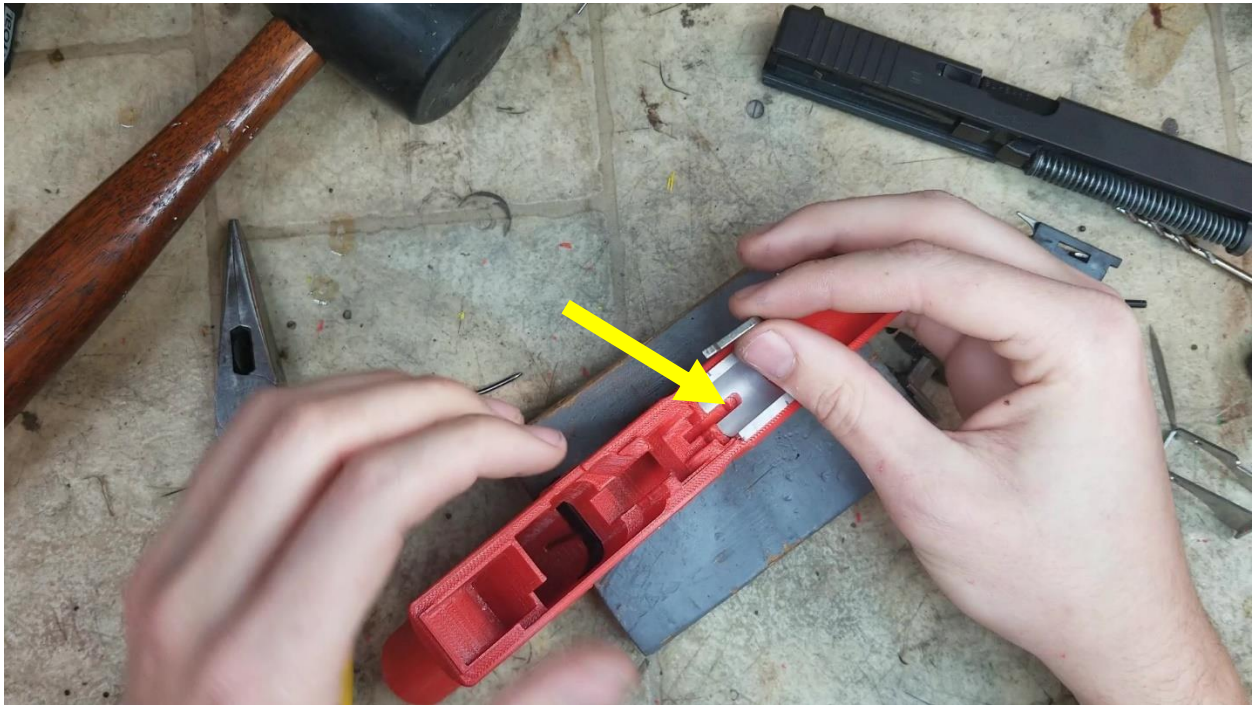

Orientation that the spring should be installed. The short end is pointing down towards the frame. The arrow shows the hole the spring goes into.

Press the spring down into this hole as far as it will go. Note that this hole is at an angle, so the end of the spring will be sticking up at an angle – this is acceptable and correct.



Spring fully inserted

Next up, take a screwdriver and your slide latch. Using the screw driver, press the end of the spring down (towards the bottom of the frame) as far as it goes. While holding the spring there, you will need to take the slide latch (with the trapezoid side facing up, and the hooked side of the slide latch facing the magwell of the frame [as opposed to the front/muzzle end of the frame]). Watch the video if you are unsure what this means. When the spring is pressed down, you should be able to position the slide latch into the rectangular cutout in the frame such that the slide latch is centered in the frame. Release the spring gently and it should lock the latch in place. The latch should move freely, though these slide latch springs can be stiff. Cycle the latch several times to ensure it moves without binding up.

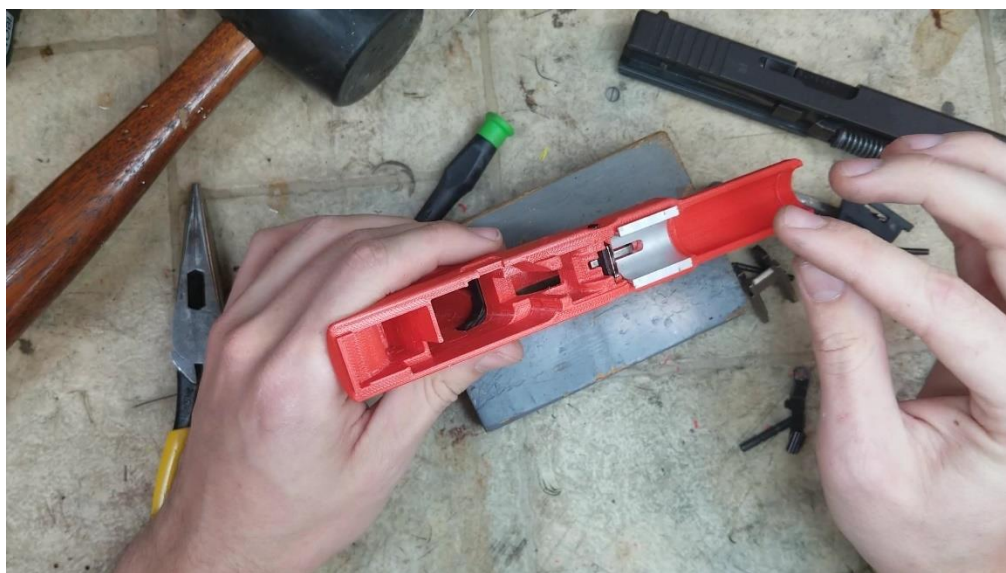

Latch installed.

B. G5Spring Frame

Take your frame, 3mmx10mm spring, and slide latch. These parts will install like how they do on a Gen5 Glock. Starting with the spring, place it down inside the round hole in the channel that the slide latch goes inside.

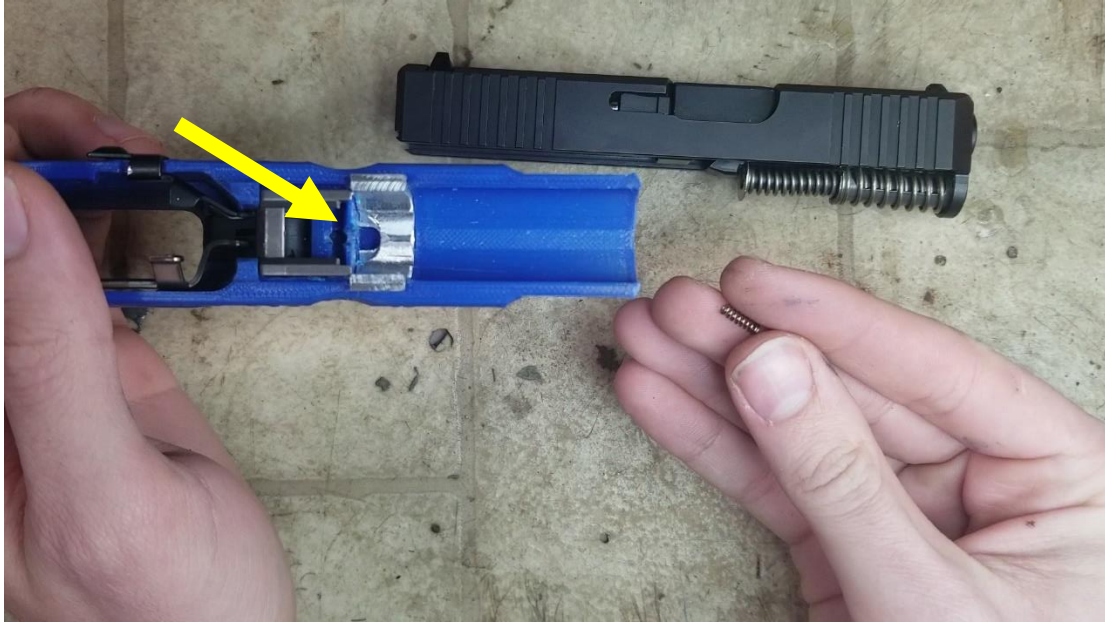

Place spring into the round pocket indicated by the arrow. It should fall freely into the hole.



Spring placed down in hole.

Next, take your slide latch (with the lip edge of on the latch facing you!) and use one end of it to push down on the spring (you can use a tool like a punch to push down on the spring if needed). While compressing the spring, push the slide latch in from the side. Once the latch is centered over the spring, the spring will lock the latch in place.



Pushing down spring with the latch



Slide latch pushed into the middle and held in by the spring. Wiggle the latch side to side to make sure the spring is holding it/you can't just push the latch out of the frame.

Note: When you want to remove the slide latch spring, use a screwdriver or punch to push down on the spring from the slot in front of the slide latch. While holding the spring down, push the latch down and to the side. It's a little tricky to get the hang of removing the latch this way, but once you figure it out it's pretty easy.



Push down on the spring from this slot in front of the slide latch. Push the latch down a hair and out the side.

Step 4: Install Rear Rails, Trigger Mechanism, And Locking Block

Take your locking block, rear rail unit, and trigger block/trigger bar/trigger assembly. Start by placing the locking block inside its recess in the frame and pushing it in as far as it will go. It should be a snug fit, but not too tight. Assuming you properly removed all the support material from this pocket, the locking block should insert far enough that you can see clear through the pin holes in the frame and locking block. If the locking block isn't all the way inserted into the pocket, these holes might not line up.



Locking block before installing



Locking block fully inserted. The holes should line up.

After ensuring the locking block can seat fully, remove it from the frame. Because it is a little snug, you might need to use a screwdriver to pry it out – you can do this easily by placing the screwdriver under the middle of the locking block from the front of the frame and levering against the slide latch spring.



Easy way to remove the locking block without breaking anything. Be gentle and wiggle the block out by hand once you've popped it most of the way out of the frame with the screwdriver.

Next, place your rear rail unit into the rear pocket of the frame by itself. If you've removed all the supports from the pocket, you should be able to push straight down on the rail and it should click into the bottom of the pocket. Once it is fully inserted you should be able to see through the rear pin hole in the frame. If the hole is close to lining up, but isn't quite perfect, ensure all support material is removed. If it is, then you may just have a slight misalignment of your frame and rail – you can and should correct this by drilling through the rails while they are in the frame in a later step. **AVOID PINCHING THE REAR RAIL UNIT CLOSED!** You can bend the rear rail unit easily, and should avoid doing so. Don't pinch the top of the unit together for any reason. When removing the rear rail, use a screwdriver to pry it upwards while levering against the top deck of the frame – don't bend the rail to remove it.

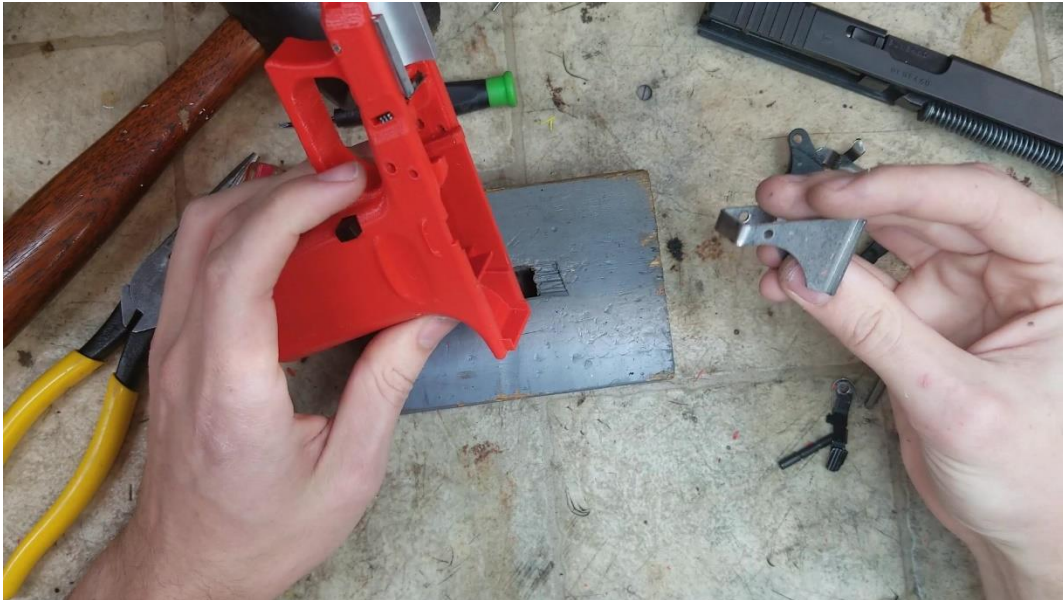

Orientation to install the rear rail. The curved side goes to the rear of the frame. The longer rail edge goes on the left hand side.



Rear rail installed. The pin hole should line up, or at least be very close to lining up.



Use a screwdriver to GENTLY pry the rear rail up enough that you can get a grip on it and wiggle it out by hand.

After ensuring the rear rail fits correctly, remove it. Take your trigger/trigger bar/trigger housing assembly. The trigger housing assembly should be placed inside the rear rail unit. You will hold these two parts together while inserting them both into the rear rail pocket at the same time.

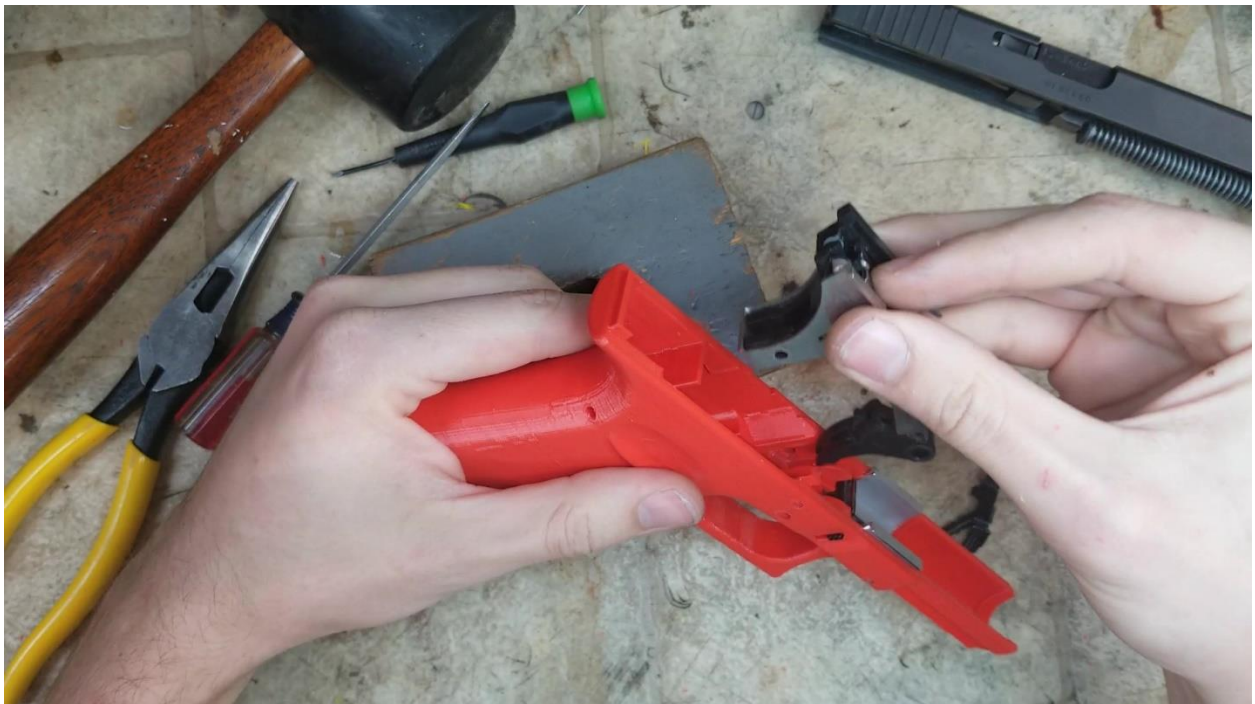

Hold the two parts together and push them down into the frame. They should fit snug in the pocket, but not tight.



Push the rail and trigger block down firmly. The trigger bar and trigger should naturally fall into the frame.

After pressing the rail and trigger block firmly into the rear pocket, check the alignment of the pin holes again. There's a chance the pin holes won't line up perfectly – because you're stacking tolerances from several different parts made via different processes, this is the one pin hole that just might not line up perfectly for you. If the holes don't want to line up, you can take your 3mm drill bit and run it through the hole (be VERY certain to hole the trigger block and rail firmly into the bottom of the pocket while drilling, set the drill to spin slow, push it into the hole slowly, and be VERY certain you keep the drill straight while doing this). Watch the video to see me demonstrate this on a frame. While you might remove a little material from the trigger block and rail, the pocket itself is what constrains their wiggle/movement – the pin itself only keeps them from falling out of the frame. So drilling this hole (as long as you do it as I described) will not harm function. Some Polymer80 frames need this same thing done to them as the holes just won't want to line up.



Check pin hole alignment. Try to wiggle things around to make them line up. Drill if needed.



Recommended drilling technique. Hold the rail and block hard into the pocket. Drill gently and straight.

If you think you have your pin holes lined up without drilling (or if you drilled it to line them up), take your rear pin (the uniform profile, polymer pin) and install it into the frame. It should push in fairly easily if you drilled. If you didn't, try using a punch to install it. Wiggle the rail and trigger block when pushing the pin in to help them line up.



The correct pin to use.



Pin fully installed. It should sit slightly recessed on both sides.

Give the rail unit and the trigger block a wiggle. The trigger block might rock a little front to back, as might the rail. Neither should be able to twist left or right. A little front to back wobble is normal and acceptable.



Pin fully installed. It should sit slightly recessed on both sides.

Next up, ensure your trigger is sitting down inside of the pocket in the frame. It should just naturally sit here.

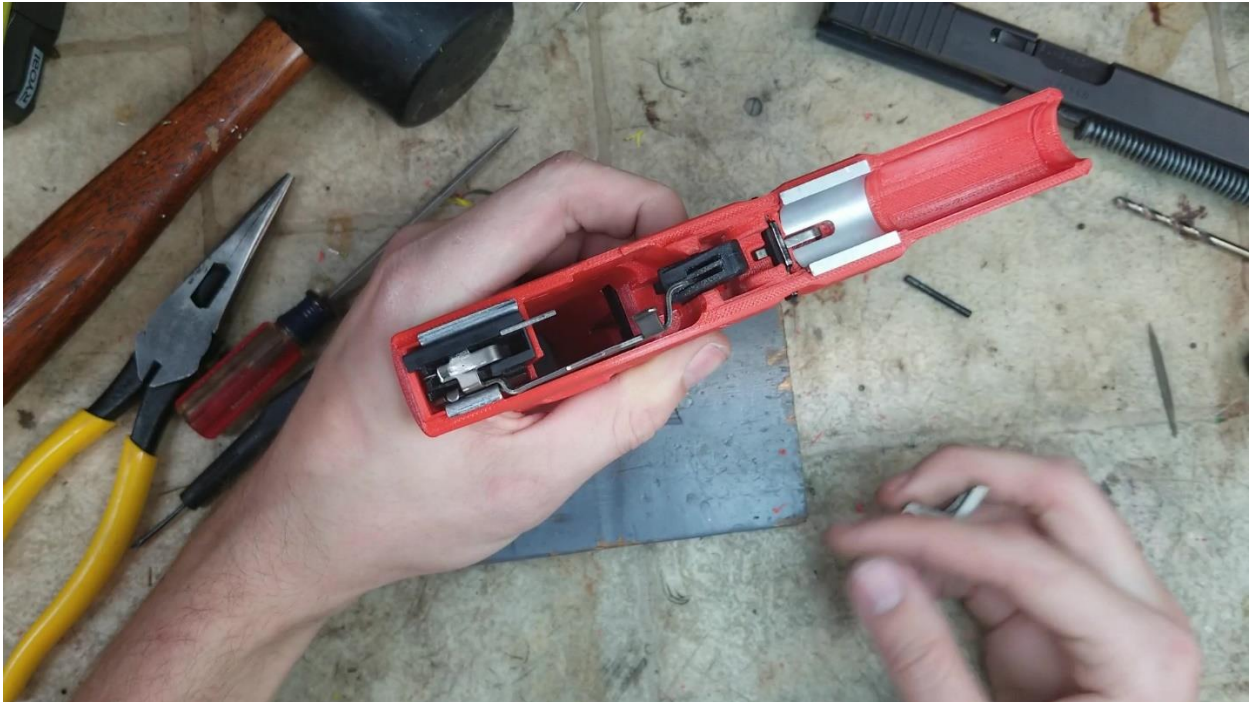

Trigger sitting inside the pocket as it should.

Pick your locking block back up and fully insert it into the pocket while the trigger is still sitting in it's place.



Locking block fully inserted.

Take the smaller of your two remaining pins (it should be sort of dumbbell shaped) and insert it into the frame. If you have trouble getting it to install, remove the locking block and using your 3mm drill bit, push the drill in and out of this top hole while spinning the drill. This should loosen up the hole enough for the pin to fit. NEVER drill through the locking block. ALWAYS make sure you hold the trigger out of the way when drilling these holes again.



The correct pin to install in the TOP hole

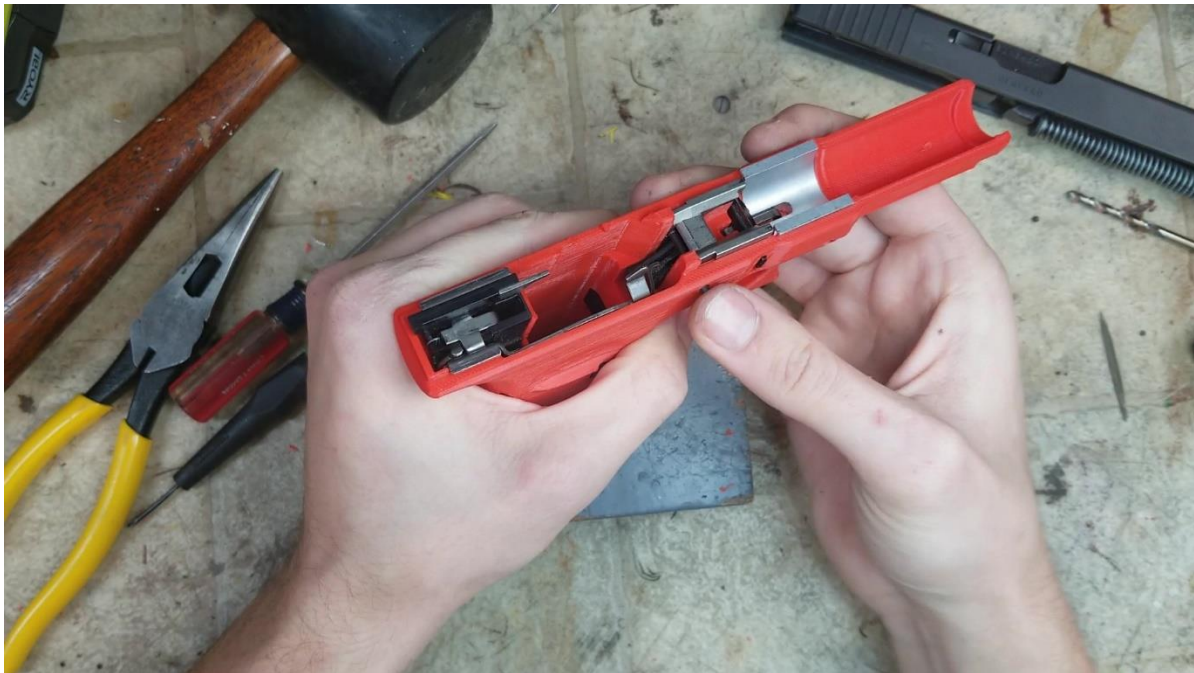

Push the pin all the way into the frame. It should sit evenly inside the frame.

Next, take your slide stop and insert it between the left side of the trigger and the frame (it goes between the left side of the trigger and the frame). The spring on the top of the slide stop will go UNDER the top pin in the locking block – ensure that the spring stays under this pin at all times.

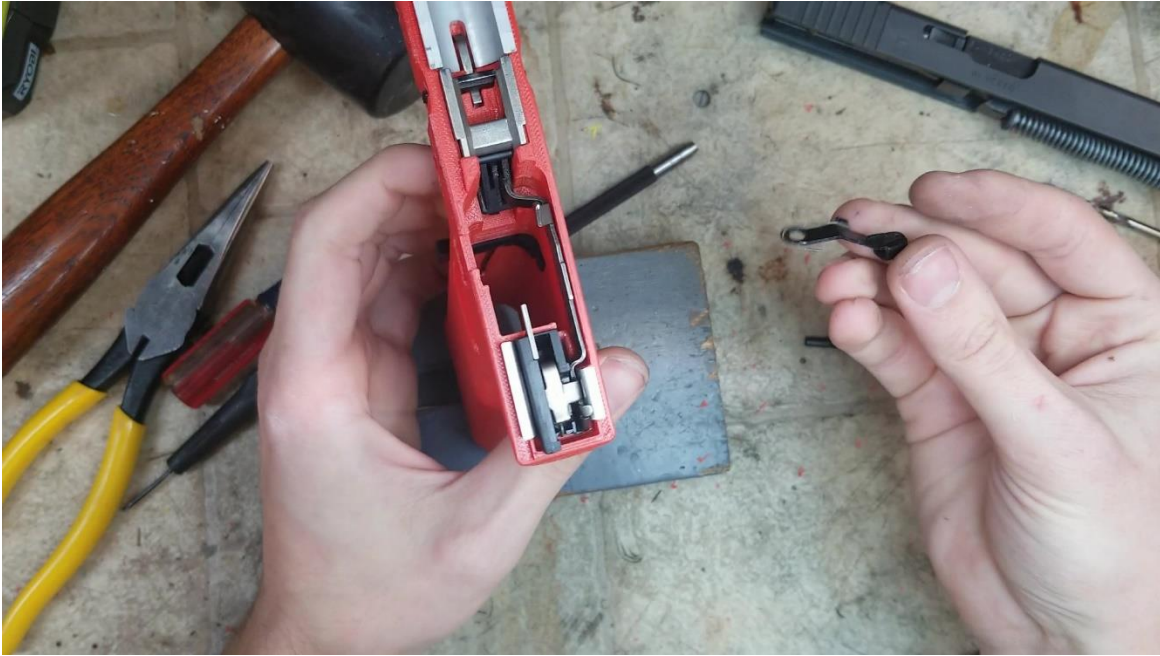

The slide stop



The slide stop being place between the trigger and frame



The hole in the slide stop should line up with the bottom hole (the last hole on the frame that doesn't have a pin).

Finally, you will take your last pin and insert it from the RIGHT side of the frame (you can insert it from the left, but it's more difficult). You may have a little trouble getting everything lined up – wiggle the pin forwards and backwards to help it line up with the locking block. If you can't get the pin to start, you will have to remove the slide stop, the top pin, then the locking block and take your 4mm drill bit in the drill. Move the drill back and forth while drilling to loosen the hole in the frame up a little. NEVER drill through the locking block. ALWAYS make sure you hold the trigger out of the way when drilling these holes again.



The last pin to install



Start the pin. Wiggle forwards and backwards to line it up with the locking block while pushing in.

As you push the pin past each component (frame, locking block, trigger, slide stop, locking block, frame), stop and make sure the next component is lined up (applicable for the trigger and slide stop, since they can move around without the pin being installed).

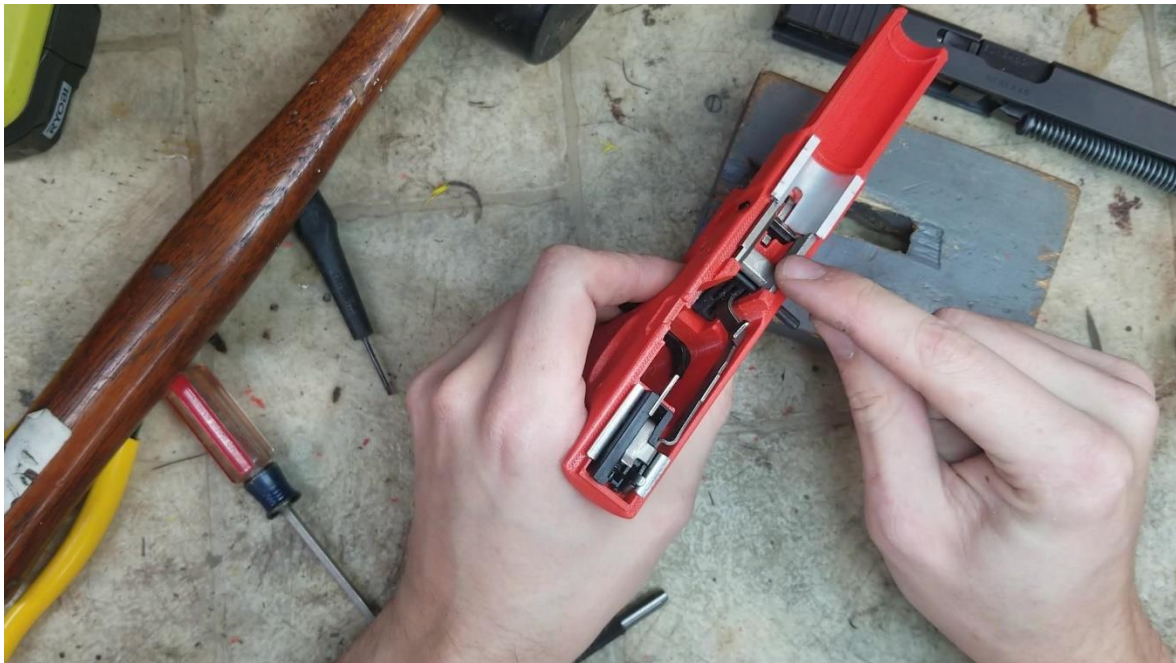

Checking the alignment of the trigger. The pin hole in the trigger must line up.



Make sure the pin hole on the slide stop lines up. You might have to wiggle it around and hold it against the spring pressure to make it line up.

Push the pin all the way. Before you push it past the slide stop, make sure the spring on the slide stop is underneath the little (top) pin in the locking block and not over the top of it. The big (bottom) pin should feel like it “clicks” into place once you’ve fully inserted it.



You may have to use a punch and a hammer to get the pin to go in. Don't hammer hard, just gently taps.



Look here to ensure the spring on the slide stop is UNDER the little pin, not OVER it.

Step 5: Install Slide, Function Test

This step is easy. Take your slide assembly (if you're not sure how a Glock slide assembly goes together and yours came disassembled, refer to a video on youtube to learn how to put it together) and guide it back onto the frame. Line up the cutouts in the slide with the rails. You may need to guide the slide past the rear rails with some care and attention (the slide will be loose enough on the front rail that it won't be guided straight into the rear rails, so you will have to align it). If your slide latch or barrel is out of spec, you may have to push down on the slide latch slightly to get the slide to go on all the way.



Guide the slide back



Slide installed. The slide latch should pop up after the slide is fully pushed back.

At this point, refer to the video to see how I do basic function testing. Rack the slide, dry fire, hold the trigger down, rack the slide, release the trigger, dry fire again. If your gun does what mine does in the video then you are good to go. The slide should be fairly easy to rack. You can use a little grease or oil on the rails to allow things to move a little more smoothly if things are tight. After a little test firing everything should break in nicely. The next section will guide you through some basic troubleshooting.

FAQ/Troubleshooting

Q: What sort of round counts should I expect? What ends up breaking?

A: Thousands, even if you print in PLA+. If you magdump more than 150 rounds without a cooling break on a PLA frame, you will melt the spring seat and the frame will stop working right – so don't do excessive mag dumps without allowing time for things to cool if you print in PLA. In Glass-Filled Zytel, you can assume that heat resistance will be on par with a factory Glock frame.

Q: What sort of reliability should I expect?

A: Reliability on my builds has been great. From what I've seen, reliability with these sorts of builds depends on the parts you use. With OEM parts and OEM mags, these frames run amazingly (I have 1600 rounds on a G22 on one of these frames without issue). With aftermarket slides, barrels, and other parts you can sometimes run into little issues like failures to eject or extract.

Q: What can I do about the rough finish where supports were touching the frame?

A: Get a cheap soldering iron from Amazon and use it to remelt the rough patches. It's very easy to do, leaves a nice, smooth finish, and takes little time (especially when compared to sanding).

Q: Why can't I get the slide on?

A: You likely don't have your rails installed correctly – go back and ensure they are installed properly. Also ensure the frame isn't warped – if your frame warps badly enough, the rails won't line up.

Q: Why is it hard to rack the slide?

A: A couple things could be causing this. You might just need a little grease/oil on the rails and some time to break the gun in – you can do this by manually racking the slide or by live fire. It could be that your rails are out of spec or damaged when you installed them – ensure there are no burrs/sharp edges on the rails. Another thing to check is if the slide rubs against the frame at any location – if the frame warped during printing, it can rub on the slide and cause issues. This warp will show up at the muzzle end of the frame, especially at the bottom of the 'U' shape on the slide. If the slide drags on that area, you can take sandpaper or a Dremel tool and remove a little plastic so that the slide doesn't drag any more. If you have to remove a ton of material, you may want to reprint your frame with settings that will combat that warp (less cooling fan).

Q: What parts work?

A: Anything that should work with a Polymer80 or factory Glock frame.

Q: What mags work?

A: Stick with OEM mags when possible. ETS and PMAGs work decently. I've had Menendez mags (3d printed) outperform PMAGs in terms of reliability in these frames, though close attention to settings must be paid when printing Menendez mags and they do wear out faster than PMAGs.

Q: I printed upright. What should I do to smooth out the underside of the frame?

A: It's best to use a soldering iron. A cheap one from Amazon will do fine. Get it hot and use it to melt the rough areas to a smooth finish. Start slow and get a feel for how the plastic will melt, then move across the bottom of the frame and smooth everything out. This method is quick, easy, very effective, and will actually make your frame just a little stronger. Avoid using this method with ABS, as harmful fumes could be released. This method should be safe with PLA/PLA+, Nylon, PETG, and several other polymers.

Q: Holster Compatibility?

A: You're in luck! These frames may have P80 grip angles/style, but they have an OEM trigger guard and OEM overall dimensions – so these work in holsters that would fit OEM Glocks. I've confirmed this with a couple Aliengear and Vedder holsters, where fit has been good.

Q: What filament should I use if I want a really strong frame?

A: Glass filled Zytel, printed hot (290-300C). Use a soldering iron to melt all the outside layers of the frame together. Doing this will leave you with a frame that is very comparable to OEM in terms of durability/resistance.

(Questions continue on next page)

Q: Can I use 40SW (G22) upper assemblies on this frame?

A: Yes, even in PLA (though the increased recoil will put more stress on the frame). However, you will need to make sure the front edge of your front rail block is bobbed or chamfered. If your front rail block isn't bobbed/chamfered, don't worry – its very easy to do.

For G17 rails, these two edges need to be knocked back a little to account for the extra slide travel:

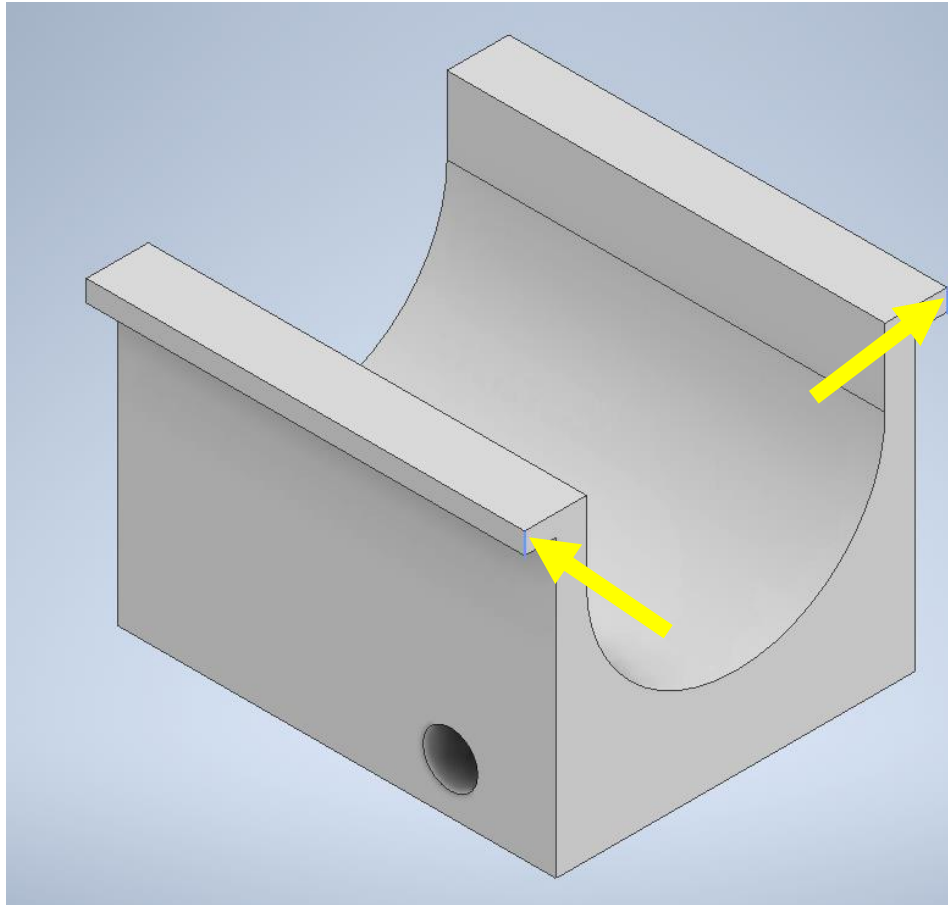

Make sure you make this change to the FRONT side of the rail block – that's the side shown, the one above/closer to the pin hole.

Here's an example of acceptable chamfer. You can use a file or Dremel tool to make angled faces on the sharp edge indicated above.

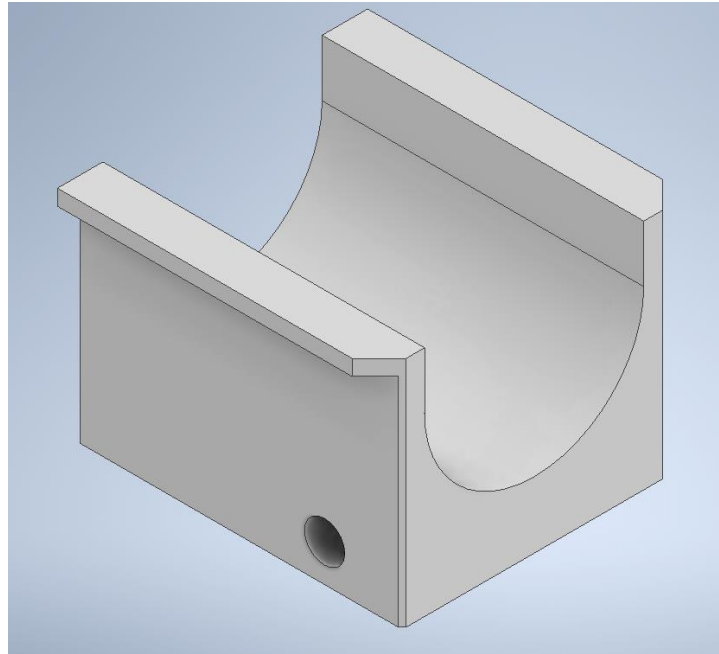

You can also try and give the front edge a little more of a rounded face – not necessary, but looks nice.

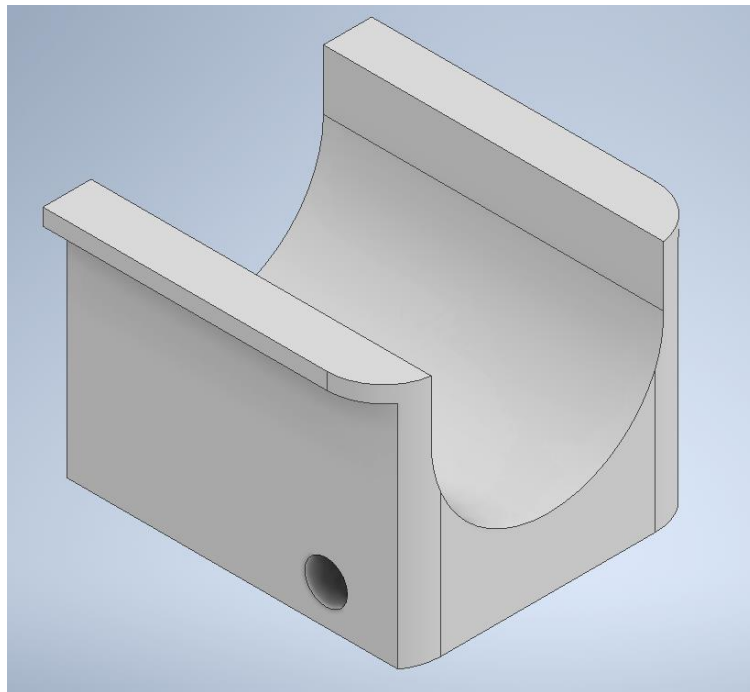

Finally, you could use a Dremel or file to create a bobbed cut into the rail block. You'll want to cut the rail BACK between 3 and 4mm, and DOWN only as far as the height that the rail sticks out of the frame (2mm or so).

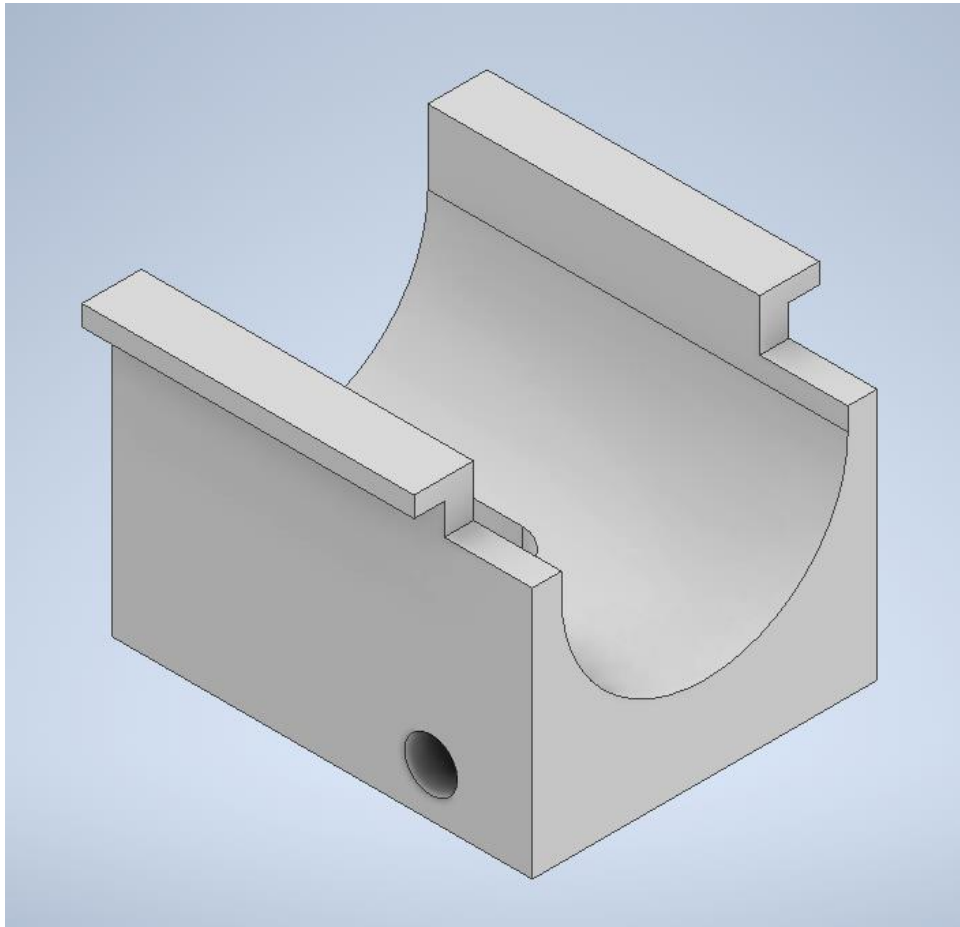

None of these cuts/changes need to be very precise – you won't be weakening the rail significantly, and so long as the front edge of the rail is taken backwards a little, it will keep the slide from crashing into the rail and keep the gun running smoothly.

If you'd like to check how your slide and rail fit, what you can do is take your slide off, take the barrel and recoil spring out, then install the slide without the barrel or spring. Push the slide all the way back until it can't go any further – at this point, the slide is touching the rail. Use a marker or knife to make note of where the front face of the slide is in relation to the frame. Take the slide off, then reinstall the barrel and spring. Install the slide and pull it as far rearward as you can. Ideally, your slide will have stopped moving BEFORE the mark that you made when you didn't have the barrel and spring installed. If this is true (with the barrel and spring installed, the slide cannot be pushed back as far as it was when you didn't have the barrel and spring installed), your rail is properly clearanced and 40SW uppers will work fine. If your slide stops in the same place, then your slide is still stopping on the rail – you might want to knock the front edge of your rail back some more.